

Subsidy Project of Decommissioning and Contaminated Water Management  
in the FY 2016 Supplementary Budgets

# **Upgrading of Approach and Systems for Retrieval of Fuel Debris and Internal Structures**

## **Accomplishment Report for FY 2017**

**April 2018**

**International Research Institute for Nuclear Decommissioning (IRID)**

# Contents of Achievement Report FY 2017

---

- I. Research Background and Purposes
- II. Project Goals
- III. Implementation Items and Their Correlations
- IV. Schedule (Overall)
- V. Project Organization
- VI. Implementation Details
  - (1) Technical Development related to Confinement Function
  - (2) Technical Development for Dust Collection/Removal Derived from Fuel Debris
  - (3) Study on  $\alpha$  Nuclide Monitoring System for Fuel Debris Retrieval
  - (4) Study on Optimization of Ensuring Safety of Methods and Systems

# I. Research Background and Purposes

## [Background]

In the project of the last fiscal year, the methods and systems for retrieving fuel debris and reactor internals (hereafter referred to as “fuel debris”) for decommissioning the Fukushima Daiichi Nuclear Power Station (NPS), were studied. In the results, feasibility issues and risks were identified [Refer to the attached documents for the project achievements (summary) of the last fiscal year(FY 2016)].

## [Purpose]

To solve identified issues, this project focuses on investigating solutions for the following issues involving the safety aspects of technologies to improve the methods and systems and conduct element tests as necessary: “Ensuring Confinement Function”, “Capture and Removal of Dust”, “ $\alpha$  Nuclide (a collective name of radioactive nuclides that emit  $\alpha$  ray) Monitoring.” By reflecting results of such technical development and results of reviews from related projects, ways to optimize (e.g. revisiting and re-evaluating previous term’s review items, comparatively evaluating the methods and systems, and reviewing the overall scenario related to fuel debris retrieval) in ensuring safety of the methods and systems in terms of exposure and maintenance, among other things, are also studied.

# I. Research Background and Purposes (Relations with Project in the Last Fiscal Year)

The project in this fiscal year and the last fiscal year are as shown below.

The components of this project [(1) through (4) below] can be classified into two categories [(i) and (ii) below].

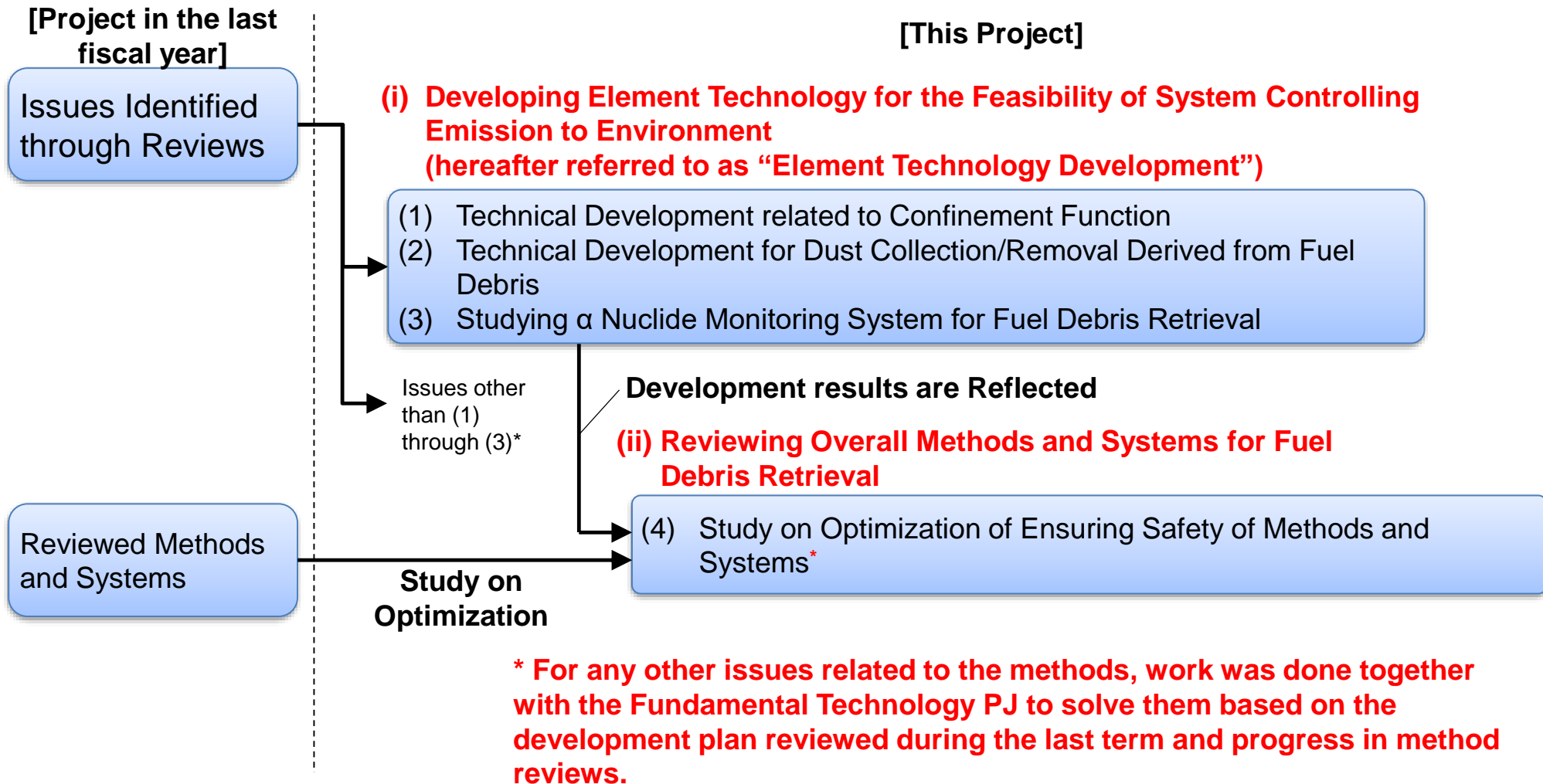

# I. Research Background and Purposes (Scope of Element Technology Development)<sup>4</sup>

- The figure below shows the scope of element technology development planned in this project.
- For the study on system optimization, safety-related systems (including facilities for addressing problems in case of failures) are within the scope of our review. (results of other projects are also reflected, including the criticality control PJ.)

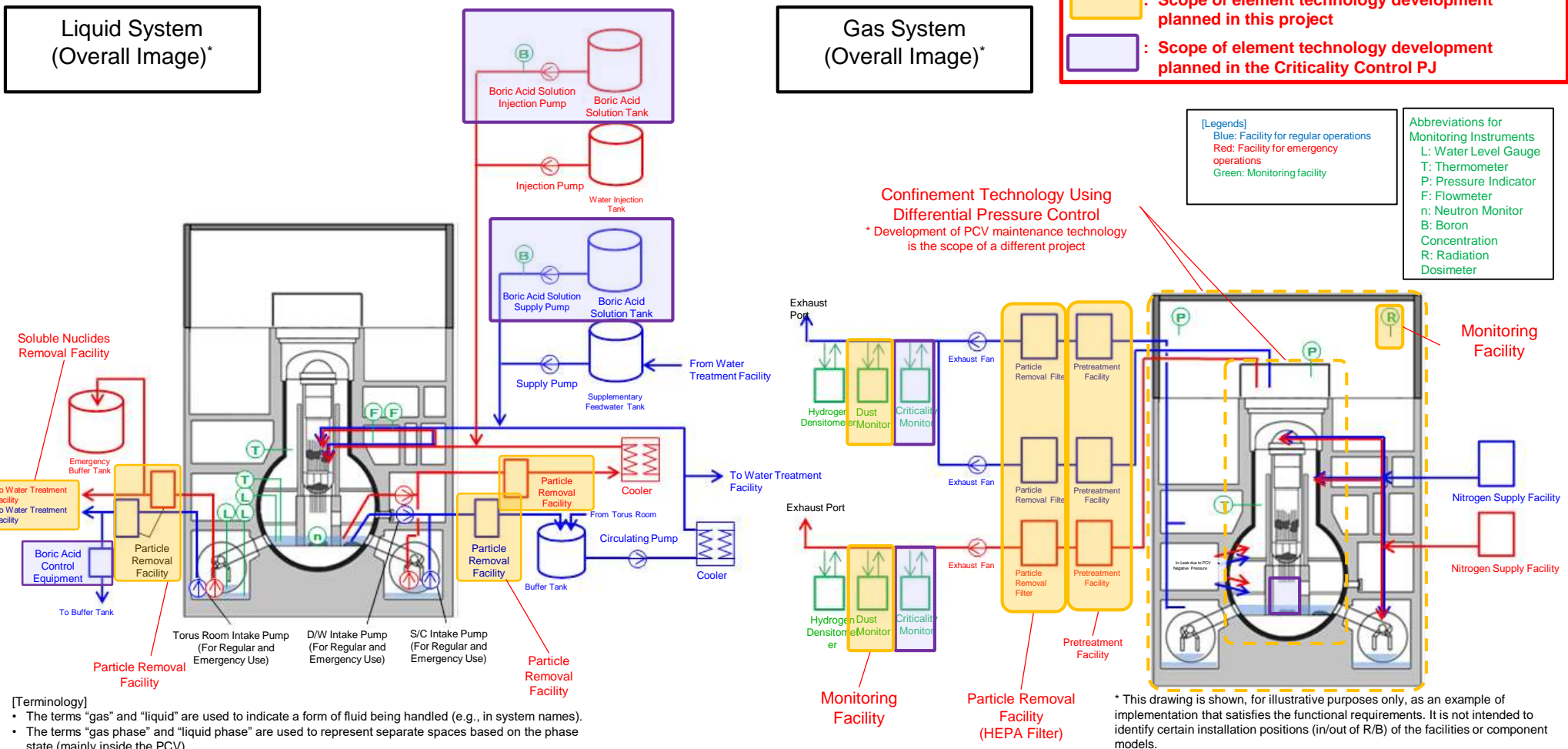

## II. Project Goals

The project focuses on completing the conceptual study of the methods and systems. Required technologies are developed, comparative evaluation in terms of exposure/maintainability is conducted, and optimization for ensuring the safety of debris retrieval to solve issues that involve the safety assurance aspects of technologies for improving the methods and systems, such as “Ensuring Confinement Function,” “Capture and Removal of Dust,” “ $\alpha$  Nuclide (a collective name of radioactive nuclides that emit  $\alpha$  ray) Monitoring” is studied.

Specific objectives for each project item are shown on the following slides.

### **[Major Project Items(Based on the Application Form of Subsidy Projects)]**

- (1) Technical Development related to Confinement Function
  - (i) Technical Development for Ensuring Confinement Function
  - (ii) Technical Development for Dose Reduction\*
- (2) Technical Development for Dust Collection/Removal Derived from Fuel Debris
  - (i) Technical Development for Reducing and Removing Radioactive Materials in Gas Phase System
  - (ii) Technical Development for Reducing and Removing Radioactive Materials in Liquid Phase System
- (3) Studying  $\alpha$  Nuclide Monitoring System for Fuel Debris Retrieval
  - (i) Conceptual Study and Development Planning of Detection Technologies and Systems for  $\alpha$  Nuclides in the Gas Phase
  - (ii) Conceptual Study and Development Planning of Detection Technologies and Systems for  $\alpha$  Nuclides in Liquid Phase
- (4) Study on Optimization of Ensuring Safety of Methods and Systems

\* Dose reduction is regarded as one of the indicators for method and system optimization, and therefore “(1) (ii) Technical Development for Dose Reduction” has been integrated reviewed together with the Item (4).

[The corresponding item number is not listed in “IV. Project Items” of this document.]

## II. Project Goals

<b>(1) Technical Development related to Confinement Function</b>	
<p>(i) Technical Development for Ensuring Confinement Function</p>	<p>To set conditions for controlling the differential pressure inside the building and PCV.</p> <p>To confirm the effectiveness of differential pressure control, ensuring the confinement function and preventing hydrogen accumulation, fire, and explosions inside the PCV.</p> <p>To study measures to improve the sealability of the building/PCV and confirm their effectiveness.</p> <p>(Target TRL upon completion: Level 3)</p>
<p>(ii) Technical Development for Dose Reduction</p>	<p>To establish a scenario for dose reduction for the public and workers during the fuel debris retrieval work, or in the case of an accident, and evaluate estimated exposure dose.</p> <p>(Target TRL upon completion: Level 3)</p>

## II. Project Goals

<b>(2) Technical Development for Dust Collection/Removal Derived from Fuel Debris</b>	
(i) Technical Development for Reducing and Removing Radioactive Materials in Gas Phase System	To study effective dust capture and collection methods as part of the cleaning function of the gas phase system while taking ensuring safety and waste reduction into account. (Target TRL upon completion: Level 3)
(ii) Technical Development for Reducing and Removing Radioactive Materials in Liquid Phase System	To study effective methods for capturing and collecting insoluble and soluble radioactive materials ( $\alpha$ nuclides) as part of the cleaning function of the liquid phase system while taking ensuring safety and waste reduction into account. (Target TRL upon completion: Level 3)



## II. Project Goals

<b>(3) Studying <math>\alpha</math> Nuclide Monitoring System for Fuel Debris Retrieval</b>	
<p>(i) Conceptual Study and Development Planning of Detection Technologies and Systems for <math>\alpha</math> Nuclides in the Gas Phase</p>	<p>To study monitoring systems based on the existing technologies for monitoring <math>\alpha</math> nuclides in the gas phase.</p> <p>To identify issues involving the monitoring system for <math>\alpha</math> nuclides in the gas phase in preparation for fuel debris retrieval, and draw up a future development plan.</p> <p>(Target TRL upon completion: Level 3)</p>
<p>(ii) Conceptual Study and Development Planning of Detection Technologies and Systems for <math>\alpha</math> Nuclides in Liquid Phase</p>	<p>To study the monitoring system based on the existing technologies for monitoring <math>\alpha</math> nuclides in the liquid phase.</p> <p>To identify issues involving the monitoring system for <math>\alpha</math> nuclides in the liquid phase, in preparation for fuel debris retrieval, and draw up a future development plan.</p> <p>(Target TRL upon completion: Level 3)</p>

## II. Project Goals

### **(4) Study on Optimization of Ensuring Safety of Methods and Systems**

To study optimization ways that take technical development results of this project, as well as results of other projects, into account to ensure safety of the methods and systems.

(Target TRL upon completion: Level 4)

#### <Supplemental Information> Definitions of Technology Readiness Level (TRL)

Level	Definition Pertinent to This Project	Phase
7	Stage at which practical applications are realized.	Practical Use
6	Stage at which on-site validations are performed.	Field Trial
5	Stage at which a prototype is manufactured based on the actual installation and validations are performed in a simulated environment at a plant, etc.	Simulated Trial
4	Stage at which functional tests are performed on a test manufactured machine as part of development and engineering processes.	Practical Application Research
3	Stage at which development and engineering work is performed by applying and combining conventional experiences. Stage at which development and engineering work is performed based on basic data in an area where conventional experiences are virtually non-existent.	Applied Research
2	Stage at which development and engineering work is performed and required specifications are developed in an area where applicable conventional experiences are virtually non-existent.	Applied Research
1	Stage at which basic information on a development and engineering object is identified.	Basic Research

### III. Implementation Items and Their Correlations (Implementation Item)

- The following issues related to the feasibility of the methods and systems for fuel debris retrieval based on past reviews conducted by last year was identified.
  - <Particularly Important Issues for Satisfying the Safety Requirements>
  - Ensuring Confinement Function
  - Capture and Removal of Fine Radioactive Particles
  - Monitoring Fine Radioactive Particles (Especially  $\alpha$  Nuclides)
- In FY 2017 and FY 2018, the development of element technologies are planned for solving the issues mentioned above and optimizing the debris retrieval methods and systems based on the results of development.

#### [Main Project Items]

##### <Developing Element Technologies for the Feasibility of the Methods and Systems>

- (1) Technical Development related to Confinement Function
- (2) Technical Development for Dust Collection/Removal Derived from Fuel Debris
- (3) Studying  $\alpha$  Nuclide Monitoring System for Fuel Debris Retrieval

##### <Study on Overall Methods and Systems>

- (4) Study on Optimization of Ensuring Safety of Methods and Systems

### III. Implementation Items and Their Correlations (among Implementation Items)

It is necessary to ensure the system is equipped with the confinement (emission control) function to provide radiation protection. In this project, element development of important items is conducted as input conditions for the system review [implementation items (1) through (3)] and the reflection of the results in the methods and systems [implementation item (4) ] is planned.

#### Input Conditions (Particularly Items Related to Feasibility)

\* Some of input conditions are set in cooperation with other projects

[Terminology] DF: Decontamination Factor

#### Review Flow (Facility Specification)

#### Output (Examples)

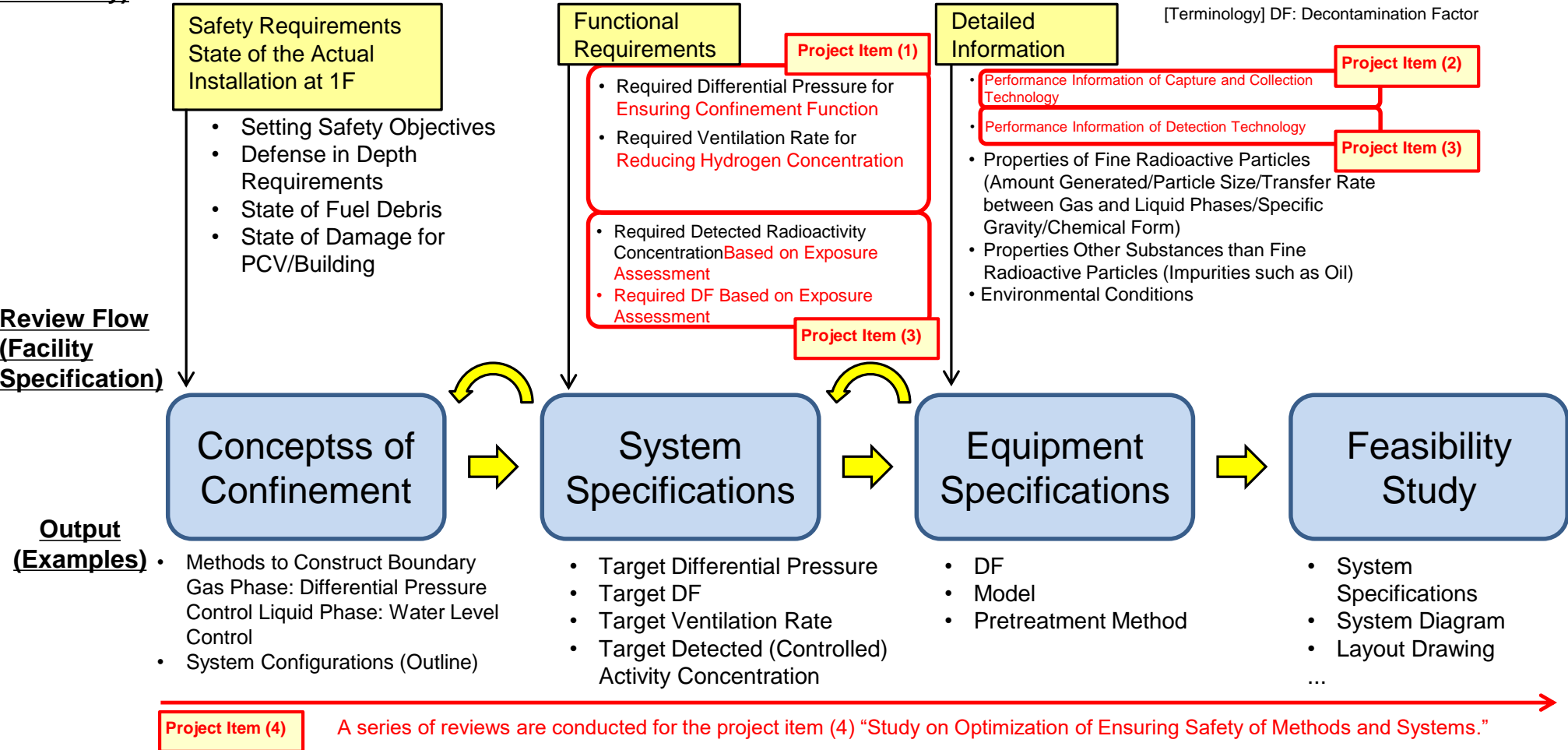

### III. Implementation Items and Their Correlations (with Other Research Projects)

- The project shares the conditions to be studied (concepts of safety, element technology, etc.) with other projects.

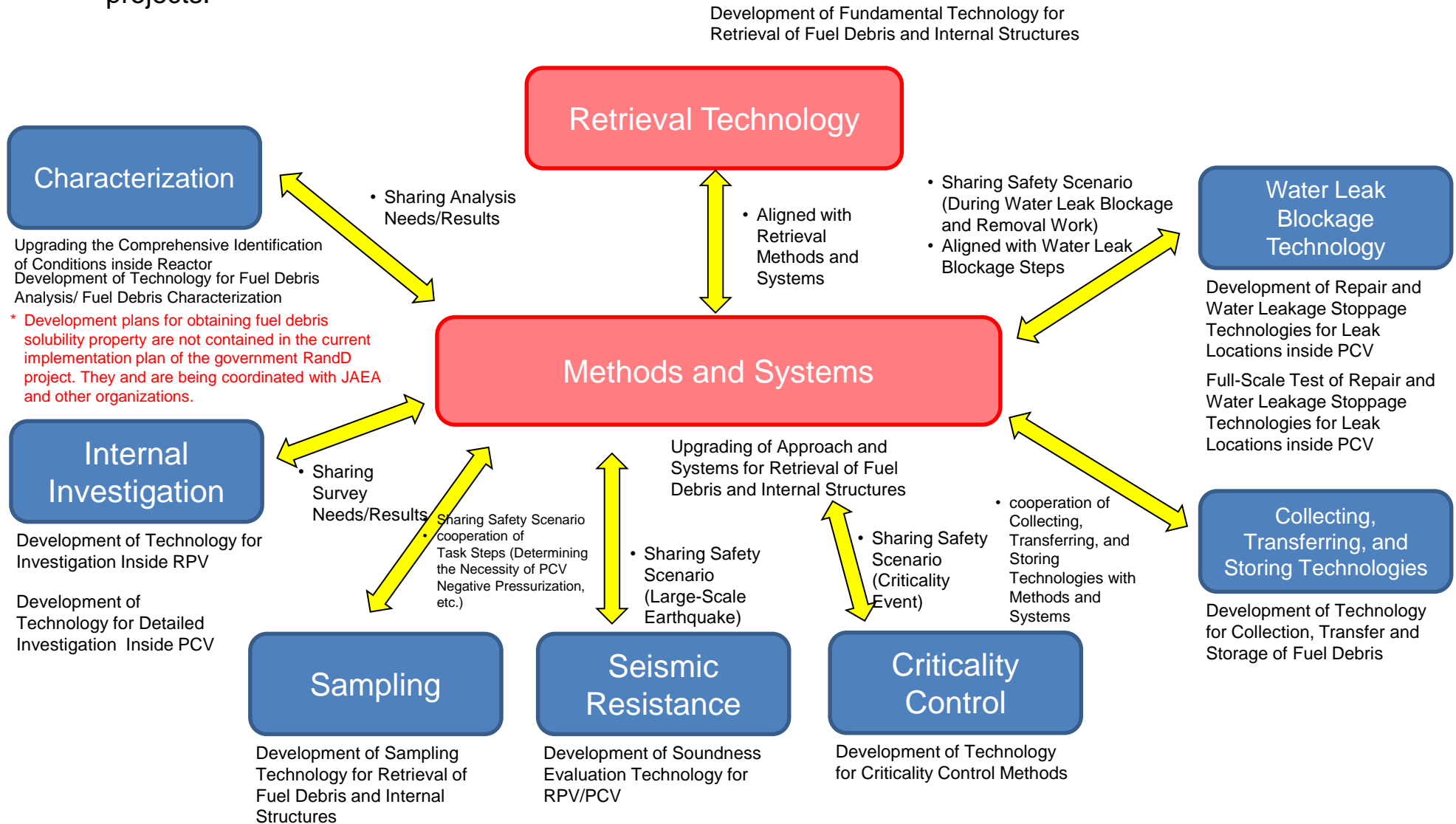

### III. Implementation Items and Their Correlations (with Other Research Projects)

➤ The table below shows the results from cooperation with other projects.

No.	Partner Projects	Description	Cooperation Method*	Input/Output from This Project
1	Fundamental Technology Project	<ul style="list-style-type: none"> <li>• Reflect technologies (in general) being developed by Fundamental Technology Project in method reviews of this project.</li> <li>• Reflect technologies (mainly processing technology and local collection facility) being developed by Fundamental Technology Project in system reviews.</li> </ul>	Hold regular joint project meetings (once a month).	Input: Amount of particles generated by processing debris and their particle size, etc. Output: Requirements for collecting data during processing technology development, etc.
2	Sampling Project	<ul style="list-style-type: none"> <li>• Submit requests to Sampling Project for information necessary in reviewing the methods and systems.</li> </ul>		Input: Sampling plan (PCV pressure, etc.) Output: Requests related to sampling
3	Criticality Control Project	<ul style="list-style-type: none"> <li>• Share the point of view concerning safety, etc., in reviews.</li> <li>• Share (align) the specifications in consideration of interfacing the components/system.</li> </ul>	Participate in the meetings mentioned in Nos. 1 and 2 as appropriate.	Input: Point of view concerning safety in criticality control, neutron detector specifications, and system specifications etc. Output: Conditions to be reviewed for gas monitoring (exhaust flow rate, etc.)
4	Internal Investigation Project	<ul style="list-style-type: none"> <li>• Submit requests to the Internal Investigation Project for information necessary in reviewing the methods and systems.</li> <li>• Reflect the results of internal investigation in method and system reviews.</li> </ul>	Hold inter-project meetings as necessary.	Input: Results of internal investigation (debris locations, etc.) Output: Requests for internal investigation
5	Debris Characterization PJ Comprehensive Identification of Conditions Inside Reactor Project	<ul style="list-style-type: none"> <li>• Receive documents and other materials about the behaviors of <math>\alpha</math> nuclides during debris processing (the details and timing are being coordinated) and reflect such information in methods and systems reviews.</li> </ul>		Input: Composition of debris, transfer rate from liquid to gas phase, etc. Output: Temperature condition for retrieval, etc.
6	Collecting, Transferring, and Storing Technologies PJ	<ul style="list-style-type: none"> <li>• Reflect the size of storage canister, restrictions on hydrogen countermeasures, etc., in method reviews.</li> </ul>		Input: Storage canister specifications, etc. Output: Retrieval amount, etc.
7	PCV Repair Project (Repair Technology/Full-Scale)	<ul style="list-style-type: none"> <li>• Share safety requirements for debris retrieval to align the PCV repair (leak blocking) plan with the methods and systems.</li> </ul>		Input: Feasible PCV water level and PCV repair methods Output: PCV pressure (differential pressure) and exhaust flow rate
8	Seismic Resistance Project	<ul style="list-style-type: none"> <li>• Share understanding of the spreading effects of system configurations and earthquakes on debris retrieval and review safety scenarios.</li> </ul>		Input: Seismic evaluation result and estimation of large-scale component damage Output: System configurations for debris retrieval

\* Results of IRID's internal discussions are shared in regard to general or Input/Output information.

# IV. Schedule [Process Chart (1/3)]

Upgrading of Approach and Systems for Retrieval of Fuel Debris and Internal Structures - FY 2017 Implementation Schedule [As of End of March]

Category (1/3)	Subcategory	FY 2017												FY 2018											
		Apr	May	Jun	Jul	Aug	Sep	Oct	Nov	Dec	Jan	Feb	Mar	Apr	May	Jun	Jul	Aug	Sep	Oct	Nov	Dec	Jan	Feb	Mar
1. Technical Development related to Confinement Function i. Technical Development for Ensuring Confinement Function (i) Element Test for Differential Pressure Control Effective for Dust Confinement	a. Specification Review/Test Plan	Test Plan												Test Equipment Manufacturing											
	b. Test Equipment Manufacturing	To Category 4												Element Test											
	c. Element Test	To Category 4												Summary											
	d. Summary	To Category 4												To Category 4											
(ii) Analyzing Negative Pressure, Airflow Distribution, etc. of Each Boundary	a. Analysis Conditions Review	Analysis Conditions Review												Revisit Analysis Conditions											
	b. Analysis	To Category 4												Analysis											
	c. Summary	To Category 4												Reanalysis											
(iii) Technical Development for Improving Sealability	a. Review Measures/Test Plan	Review Measures/Test Plan												Test Equipment Manufacturing											
	b. Test Equipment Manufacturing	To Category 4												Element Test											
	c. Element Test	To Category 4												Summary											
	d. Summary	To Category 4												To Category 4											
<b>Legends</b> Plan (Blue bar) Possible Acceleration (Dotted line) Postponement (Dashed line) Actual Schedule (Black bar) Line indicating linkage between items (Red dashed arrow)		<b>Major Milestones</b> ▲ Results of Solicitation ▲ Interim Report Meeting at IRID Symposium (8/3) ▲ Interim Report Meeting at IRID Symposium (10/18) ▲ End-of-Year Report Meeting (4/16) ▲ Interim Report Meeting ▲ Final Report Meeting																							

# IV. Schedule [Process Chart (2/3)]

Upgrading of Approach and Systems for Retrieval of Fuel Debris and Internal Structures - FY 2017 Implementation Schedule [As of End of March] (2/3)

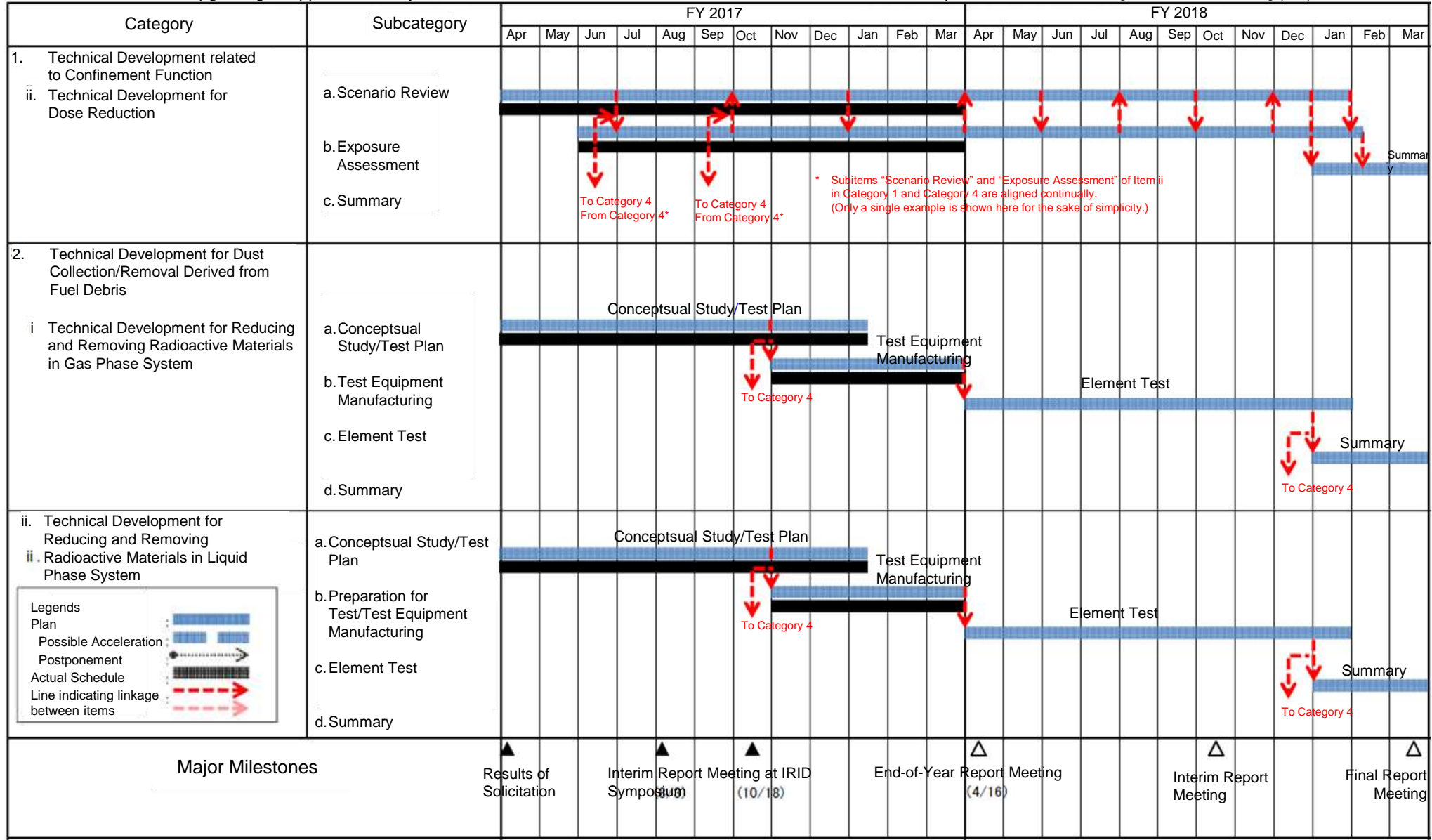

**Legends**

- Plan: [Blue bar]
- Possible Acceleration: [Dotted bar]
- Postponement: [Dashed bar]
- Actual Schedule: [Black bar]
- Line indicating linkage between items: [Red dashed arrow]



# IV. Schedule [Process Chart (3/3)]

Upgrading of Approach and Systems for Retrieval of Fuel Debris and Internal Structures - FY 2017 Implementation Schedule [As of End of March] (3/3)

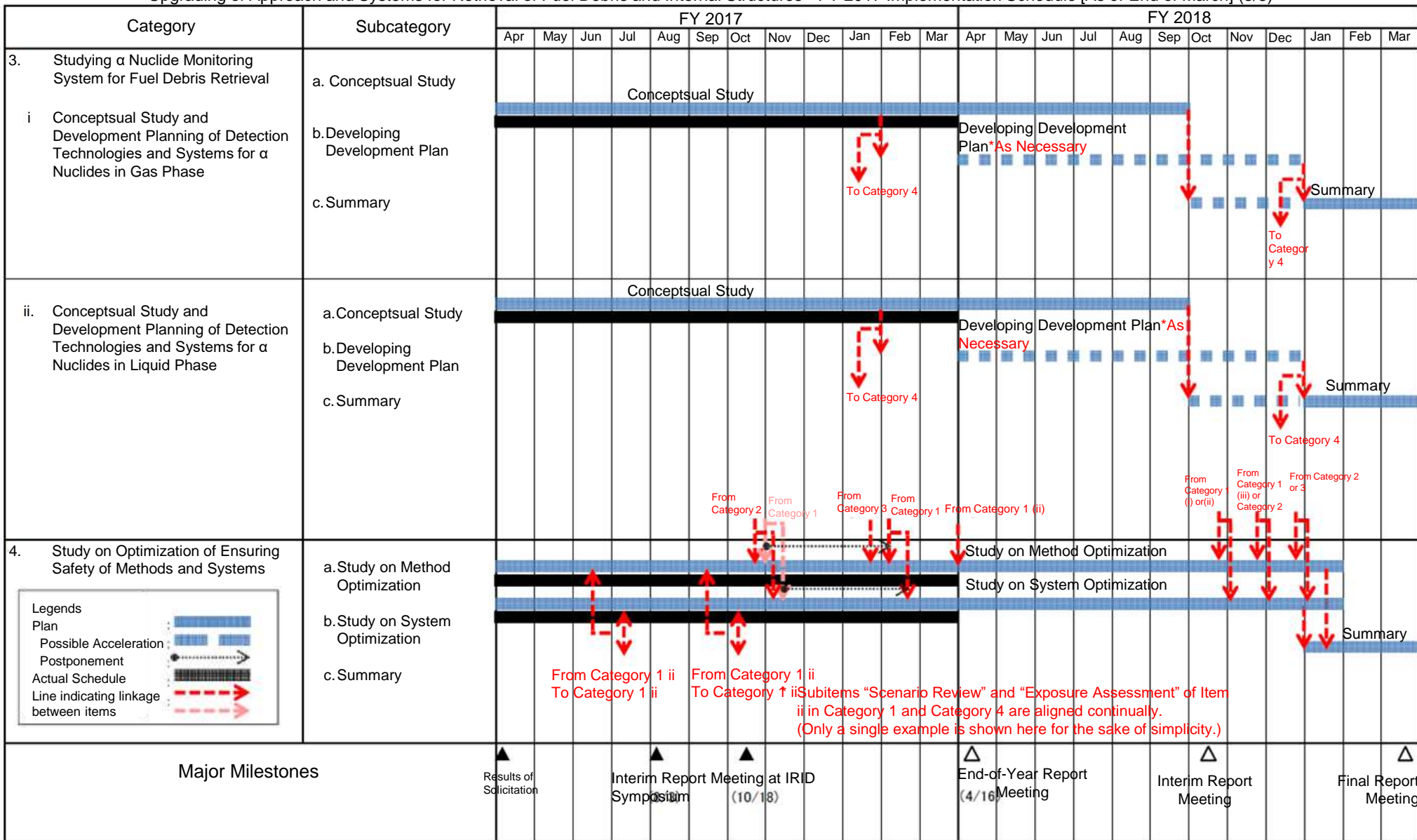

## IV. Schedule (Summary)

- The project is progressing well as scheduled at the initial planning stage.
- Although the timing for starting “Item i: Technical Development for Ensuring Confinement Function” of Category 1, was modified (delayed for about 3 months), this is not expected to affect subsequent processes or results at the time of project completion.

[Reason for Schedule Modification]

The schedule was changed to proceed more carefully by hearing from outside experts .

# V. Project Organization

Tokyo Electric Power Company Holdings, Inc.

**International Research Institute for Nuclear Decommissioning (IRID)**

- Draw up overall plans and oversee technology management
- Manage technologies, including technical development progress

**Hitachi-GE Nuclear Energy, Ltd.**

- Assist to evaluate retrieval methods and design element tests (Company A)
- Dust containment test (Company B)
- Airflow analysis inside PCV (Company C)
- Technical development for improving sealability (Company D)
- Backwash HEPA test (Cavendish Nuclear Ltd [UK])
- Particle removal performance test in liquid (Company F)
- Review debris evaluation and detecting methods (Company G)
- Pedestal reinforcement method (Shimizu Corporation)

**Toshiba Energy Systems and Solutions Corporation**

- Measure changes in nitrogen injection flow rate and PCV differential pressure(Company I)
- Analyze negative pressure and airflow distribution in each boundary (Company J)
- Review and perform element tests for measures to improve R/B sealability (Company K)
- Assist in designs related to exposure evaluation (Company L)
- Element tests for backwashable dry dust collector (Shin Nippon Air Technologies Co.,Ltd.)
- Downsize wet electric dust collector (IHI Corporation)
- Develop remote replacement technology for HEPA filters (Shin Nippon Air Technologies Co.,Ltd.)
- Element tests for sludge collection technology (IHI Corporation)
- Assist in reviews related to optimization of methods and systems (Company M)
- Assist in designs related to optimization of methods and systems (Company N)
- Assist in designs related to safety requirements and designs (MPR Associates, Inc. [US])

**Mitsubishi Heavy Industries, Ltd.**

- Assist to review confinement function (Company Q)
- Assist to review dust capture and removal (Company R)
- Assist in element tests for dust capture and removal (Company S)
- Assist to review optimization of ensuring safety of methods and systems (Company T)

## VI. Implementation Details

### (1) Technical Development Related to Confinement Function

#### (i) Technical Development for Ensuring Confinement Function

##### [Objectives]

- To confirm the system design conditions (e.g., differential pressure) effective for confinement.
- To confirm the system design conditions (exhaust amount, amount of nitrogen to fill, etc.) effective for inactivation (prevention of hydrogen combustion).
- To review technologies to improve sealability.

#### **End of Fiscal Year 2017: Evaluation of Effectiveness Using Simple Means**

- Element Test: Develop a test plan
- Simulation: Conduct a trial analysis
- Technology for Sealability Improvement: Conduct a desk study

#### **End of Fiscal Year 2018: Confirmation of Effectiveness with Element Test/Simulation**

- Element Test: Conducting a test
- Simulation: Conducting analyses
- Technology for Sealability Improvement: Conduct a desk study (continued) and mockup test as necessary

## VI. Implementation Details

### (1) (i) Technical Development for Ensuring Confinement Function

#### <Issues to be Solved by Technical Development>

- To confine dust generated by a fuel debris retrieval process, negative pressure is going to be controlled by setting up a boundary and ensuring adequate exhaust is in place that corresponds to openings within that boundary.
- To establish the confinement technology with boundary settings and negative pressure control, information about the following issues needs to be obtained.

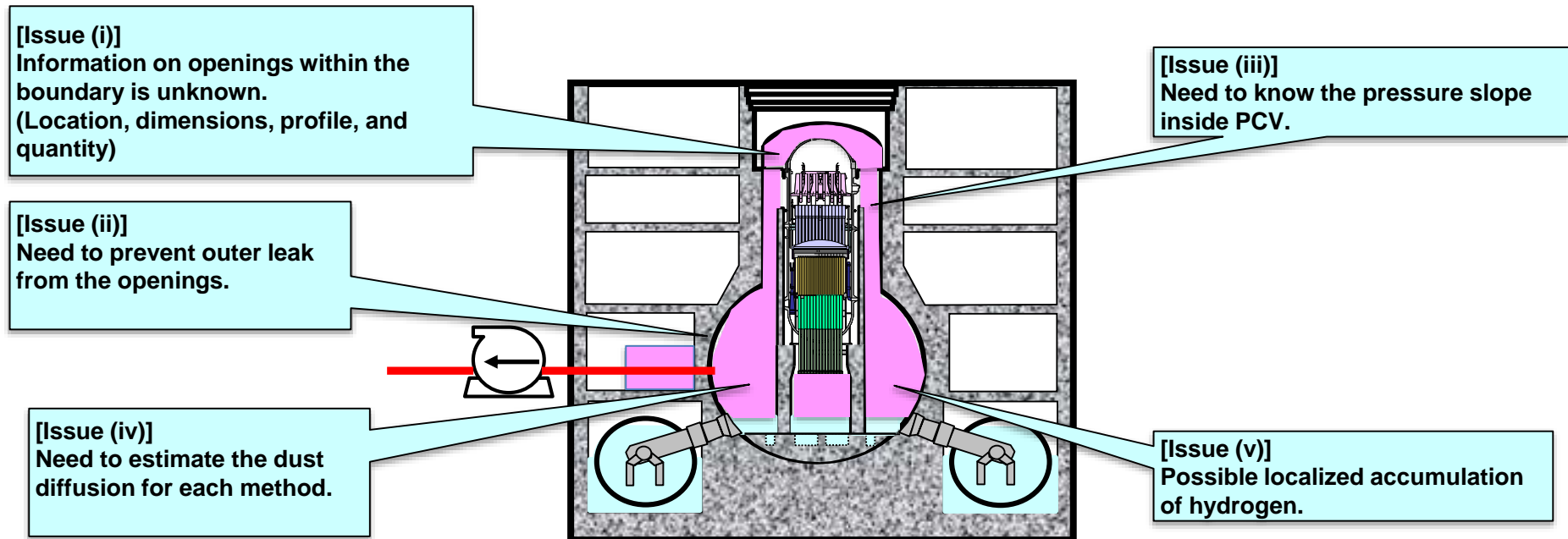

## VI. Implementation Details

### (1) (i) Technical Development for Ensuring Confinement Function

#### <Purpose and Necessity for Development>

- To review an action policy to acquire information required for the desired design with regard to issues listed on the previous page.
- To classify and clarify technical development objects into analysis, element test, and confirm actual installation.
- The objective is to establish a technology with which necessary information through analysis, element testing, and checking with actual installation can be acquired.

Issues	Information Required for Design	Analysis	Element Test	Confirm Actual Installation	Notes
(i) Information on openings within the boundary	Information on openings to determine exhaust flow rate required for maintaining negative pressure.	(Information on openings that exist in the actual installation cannot be obtained by analysis.)	(Information on openings that exist in the actual installation cannot be obtained by element test.)	Propose a test to estimate information on openings.	
(ii) Preventing outer leak from the openings	Negative pressure value at which in-leak can be guaranteed locally.	(Verify codes by comparing local simulation analysis and test results.)	Validated the negative pressure control value in element test for local simulation.	<Operation with determined differential pressure control value>	Conducted to confirm the feasibility of a dynamic boundary for a broken boundary.
(iii) Identifying the pressure slope in PCV	Confirmation that no localized uneven distribution of pressure exists to account for negative pressure control.	Evaluate the overall pressure distribution in PCV and confirm required negative pressure can be guaranteed throughout PCV.	(Confirm by analysis. Comparison of analysis and element test results are conducted under (ii).)	<Pressure monitoring at representative points>	
(iv) Estimating the dust diffusion for each method	Estimate information on the location and size of dust floating in gas phase.	Confirm the dust distribution in PCV through dust behavior analysis.	Obtain the information on dust generated by each method (Fundamental Technology Project).	<Monitoring dust concentration>	Confirm where to draw a line between local collection and collection by the system.
(v) Possible localized accumulation of hydrogen	Location of accumulated hydrogen, nitrogen flow rate effective for scavenge, and positions for injection.	Evaluate locations of accumulated hydrogen based on hydrogen distribution analysis and review the amount of nitrogen to fill and positions for injection.	(Confirm by analysis. Comparison of analysis and element test results are conducted under (ii).)	<Monitoring exhaust hydrogen concentration. Hard to measure local hydrogen concentration.>	

The angle brackets <> represent proposed measures during debris retrieval.

# VI. Implementation Details

## (1) (i) Technical Development for Ensuring Confinement Function

### <Schedule (Achievements and Future Plans)>

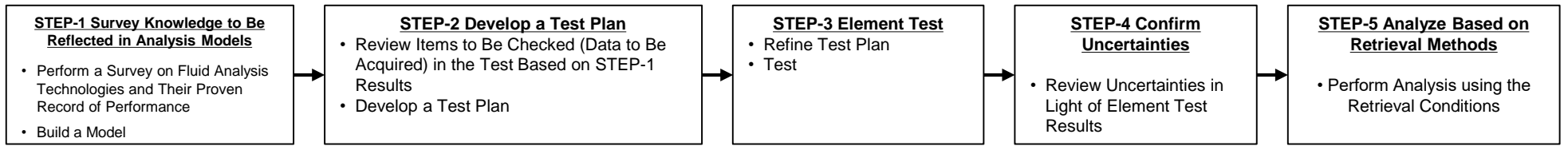

Item	FY 2017				FY 2018			
	1Q	2Q	3Q	4Q	1Q	2Q	3Q	4Q
Master Schedule		Interim Report Meeting		End-of-Year Report Meeting		Interim Report Meeting		Final Report Meeting
Survey Knowledge to Be Reflected in Analysis Models	[Bar chart showing activity from 1Q to 4Q]							
Build a Test Plan		[Bar chart showing activity from 2Q to 4Q]						
Element Test (Acquiring Data for Comparison with Analysis)				[Bar chart showing activity from 4Q to 2Q]				
Confirm Uncertainties					[Bar chart showing activity from 1Q to 2Q]			
Analyze Based on Retrieval Methods						[Bar chart showing activity from 2Q to 4Q]		
Feedback to System Studys								

## VI. Implementation Details

### (1) (i) Technical Development for Ensuring Confinement Function

#### (a) Analyzing Negative Pressure, Airflow Distribution, etc. in Each Boundary

##### 1) Purpose

To establish the 1F analysis model based on flow analysis codes (GOTHIC, CFD code, etc.), taking the differential pressure control conditions (field data) and state of damage on-site into account. To confirm effectiveness of the following items by understanding the overall airflow behavior inside the PCV:

- Confirm differential pressure control conditions and system effectiveness (in dust emission control) to ensure the confinement function.
- Confirm the possibility of hydrogen accumulation within the PCV and effectiveness of fire and explosion prevention within the PCV with inert gas supply. (Also confirm these for other areas in the building where hydrogen is likely to have been generated, including the torus room.)

##### 2) Scope of Modeling

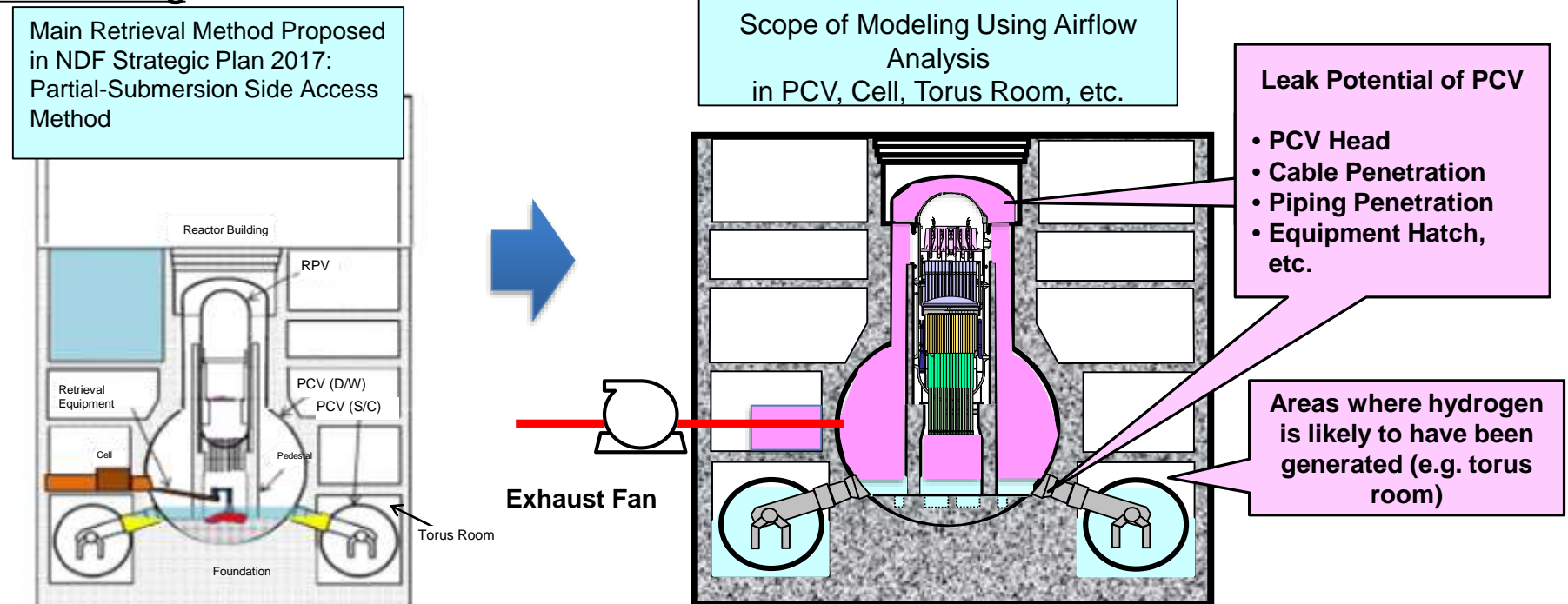



# VI. Implementation Details

## (1) (i) Technical Development for Ensuring Confinement Function

### (a) Analyzing Negative Pressure, Airflow Distribution, etc. in Each Boundary

#### 3) Selecting Analysis Codes (Example of Application for Each Evaluation Model)

	Concentration Parameter Model	Distributed Parameter Model	CFD Analysis Model
Purpose of Analysis	<ul style="list-style-type: none"> <li>• Macroscopic Evaluation of State Quantity in Space</li> <li>• Flow Evaluation between Spaces</li> </ul>	<ul style="list-style-type: none"> <li>• Microscopic Evaluation of State Quantity in Space</li> <li>• Flow Evaluation in Space</li> </ul>	<ul style="list-style-type: none"> <li>• Microscopic Evaluation of State Quantity in Space</li> <li>• Flow Evaluation in Space</li> </ul>
Example of Application	<p>[GOTHIC]</p> <ul style="list-style-type: none"> <li>• New Regulatory Requirements: Evaluation of Hydrogen Behavior in Building</li> <li>• Evaluation of Vapor Propagation (Overflow)</li> <li>• Investigation of the 1F Accident</li> <li>• Reproducing and Analyzing NUPEC ISP-35 (Developer)</li> </ul> <p>[MAAP]</p> <ul style="list-style-type: none"> <li>• Evaluation of Conformity to the New Regulatory Requirements Room Temperature Evaluation during IS-LOCA by BWR Electric Power Companies</li> <li>• Evaluation of Conformity to the New Regulatory Requirements at the Rokkasho Reprocessing Plant by JNFL</li> </ul> <p>[MELCOR]</p> <ul style="list-style-type: none"> <li>• Analyzing Boiling Events of Liquid Waste at Reprocessing Plants Using MELCOR Code: JAEA-Research2012-026</li> </ul>	<p>[GOTHIC]</p> <ul style="list-style-type: none"> <li>• New Regulatory Requirements: Evaluation of Hydrogen Behavior in Building</li> <li>• Reproducing and Analyzing 1F Reactor Water Level Gauge Behaviors</li> <li>• Reproducing and Analyzing (NRA) NUPEC ISP-35 (NRA)</li> </ul>	<p>[STAR-CD]</p> <ul style="list-style-type: none"> <li>• NUPEC Treatment of Excess Hydrogen (Studying Installation of an Ammonia Catalytic FCS Inside PCV)</li> </ul> <p>[GASFLOW-MPI]</p> <ul style="list-style-type: none"> <li>• THAI (Germany)</li> <li>• PANDA (Switzerland), etc.</li> </ul> <p>(All of these are VandV by Developers)</p> <ul style="list-style-type: none"> <li>• BWR (Switzerland, Mexico, and Germany)</li> </ul>

## VI. Implementation Details

(1) (i) Technical Development for Ensuring Confinement Function

**(a) Analyzing Negative Pressure, Airflow Distribution, etc. in Each Boundary**

**3) Selecting Analysis Codes (Applicability to Flow Evaluation Inside PCV during Debris Retrieval)**

Requirements for Modeling	Concentration Parameter Model	Distributed Parameter Model	CFD Analysis Model
Identifying the Airflow Inside PCV (Macroscopic and Microscopic)	Not Applicable	Applicable	Very Applicable
Airflow Resolution and Ease of Analysis (Sufficient Resolution and Sensitivity Analysis Are Required)	Not Applicable PCV (S/C) and Building (e.g. Torus Room)	Applicable	Somewhat Applicable
Phase Changes such as Vapor Generation and Vapor Condensation and Movement of Substances in Space	Applicable	Applicable	Somewhat Applicable
Behaviors of Aerosols (e.g. Diffusion, Natural Deposition, or Removal)	Applicable	Applicable	Somewhat Applicable
Identifying Hydrogen Behaviors (Accumulation and Substitution)	Applicable	Applicable	Applicable
Identifying Behaviors Inside the Building (Interface with the Outside of PCV)	Applicable	Somewhat Applicable	Somewhat Applicable

PCV (D/W) and Cell

PCV (S/C) and Building (e.g. Torus Room)



**GOTHIC Ver.8.2 Is Applied**

## VI. Implementation Details

(1) (i) Technical Development for Ensuring Confinement Function

(a) **Analyzing Negative Pressure, Airflow Distribution, etc. in Boundary**

### **3) Selecting Analysis Codes (Summary)**

Flow analysis codes were reviewed that are applicable in analyzing negative pressure, airflow distribution, etc. in each boundary.

- Since the behavior analysis inside the PCV requires evaluating the distribution in that space while taking into account the differential pressure control conditions and state of damage on-site, the model should identify thermal hydraulic flows by splitting the space into meshes.
- Also, although the gas inflow/outflow will be simulated on the outside of PCV (D/W) in order to understand behaviors inside the building (e.g. torus room), it is reasonable to apply the Concentration Parameter model for the sake of ease of analysis.
- As for the dust confinement function, it is necessary to evaluate aerosol behaviors as well as the airflow inside the D/W.
- Therefore, it is concluded that the GOTHIC code (latest Ver8.2) is the most appropriate for airflow analysis because it allows simultaneous application of both lumped and distributed parameters and evaluation of aerosol behaviors.  
(Aerosol behavior models incorporated in GOTHIC is currently under investigation.)

### (1) (i) Technical Development for Ensuring Confinement Function

#### (b) Element Test for Differential Pressure Control

##### 1) Purpose

To confirm the negative pressure conditions, which can guarantee in-leak locally and are effective for dust confinement, based on the element test using a simple system and review differential pressure control conditions for actual installation.

To obtain the velocity field data near the openings to help the verification of local model analysis.

##### 2) Implementation Item

- Measure the velocity field near an opening using the pressure (differential pressure between inside and outside) conditions of a container with an opening as a parameter to confirm the in-leak.  
=> **Understand the differential pressure limit and confirm the feasibility of dynamic boundary**
- Make it possible to change the dimensions, profile, and number of the openings and confirm whether the form of an opening has an impact to the negative pressure value.  
=> **Obtain estimated information on openings whose details are unknown**
- Set the parameter value to between -200 and -300 Pa specified as the pressure (differential pressure between inside and outside) condition of the primary boundary, and confirm negative pressure values that can guarantee in-leak when different values are assigned to the parameter.  
=> Use the results to evaluate the margin time until a standby machine starts up when a fan trip occurs. (Pressure variations inside the PCV during exhaust fan shutdown are obtained by analysis.)

# VI. Implementation Details

(1) (i) Technical Development for Ensuring Confinement Function

(b) Element Test for Differential Pressure Control

## 3) Test Equipment and Major Measurement Items (Proposal)

- Duplicated structure with a primary vessel (PCV simulated, 1 m square) and a secondary vessel (2 m square) => Made of acrylic for visualization
- Create openings for simulating openings generated by PCV damage => The area of the openings is adjustable
- Generate a negative pressure state by adjusting exhaust volume on the primary side => The pressure is measured
- Confirm the area near the opening of the primary vessel is also in an in-leak state  
=> The velocity field is measured using PIV (Particle Image Velocimetry)
- Prepare for a case where simulated dust particles are injected in the primary vessel  
*(Selection and representativeness of simulated particles must be discussed)*

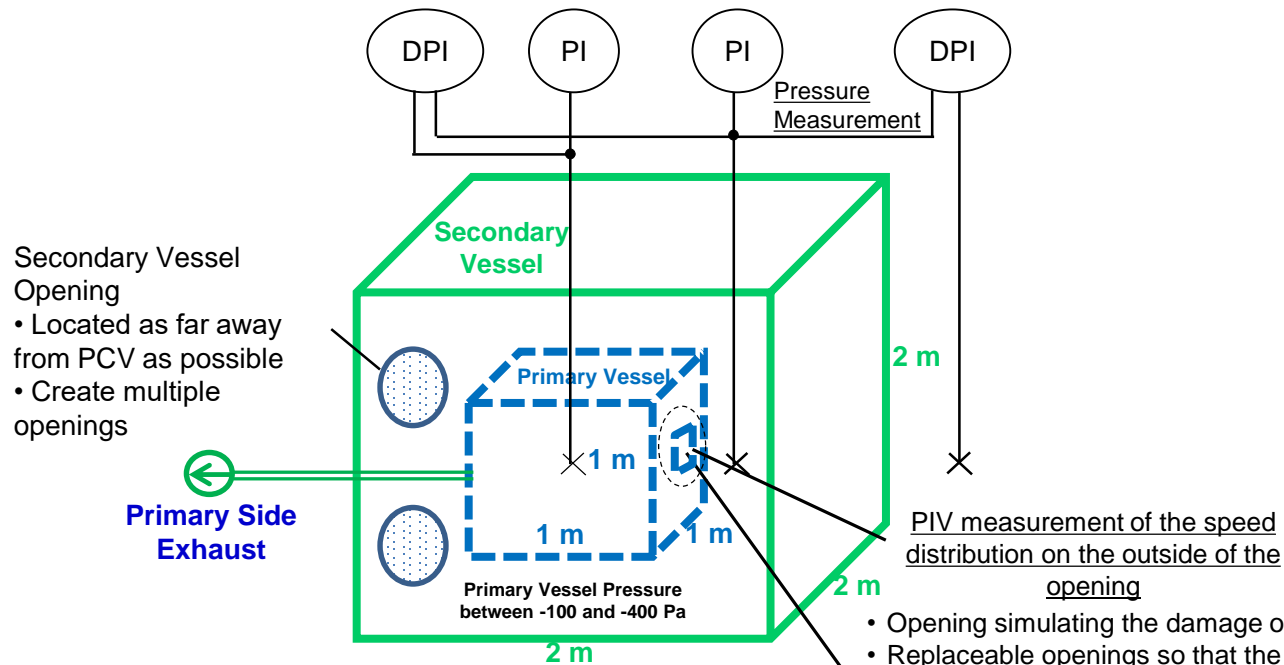

- Opening simulating the damage on PCV
- Replaceable openings so that the test can be conducted for openings with various profiles and dimensions
- Create multiple openings

## VI. Implementation Details

(1) (i) Technical Development for Ensuring Confinement Function

(b) Element Test for Differential Pressure Control

### 4) Image of Measuring Velocity Field and Test Parameter

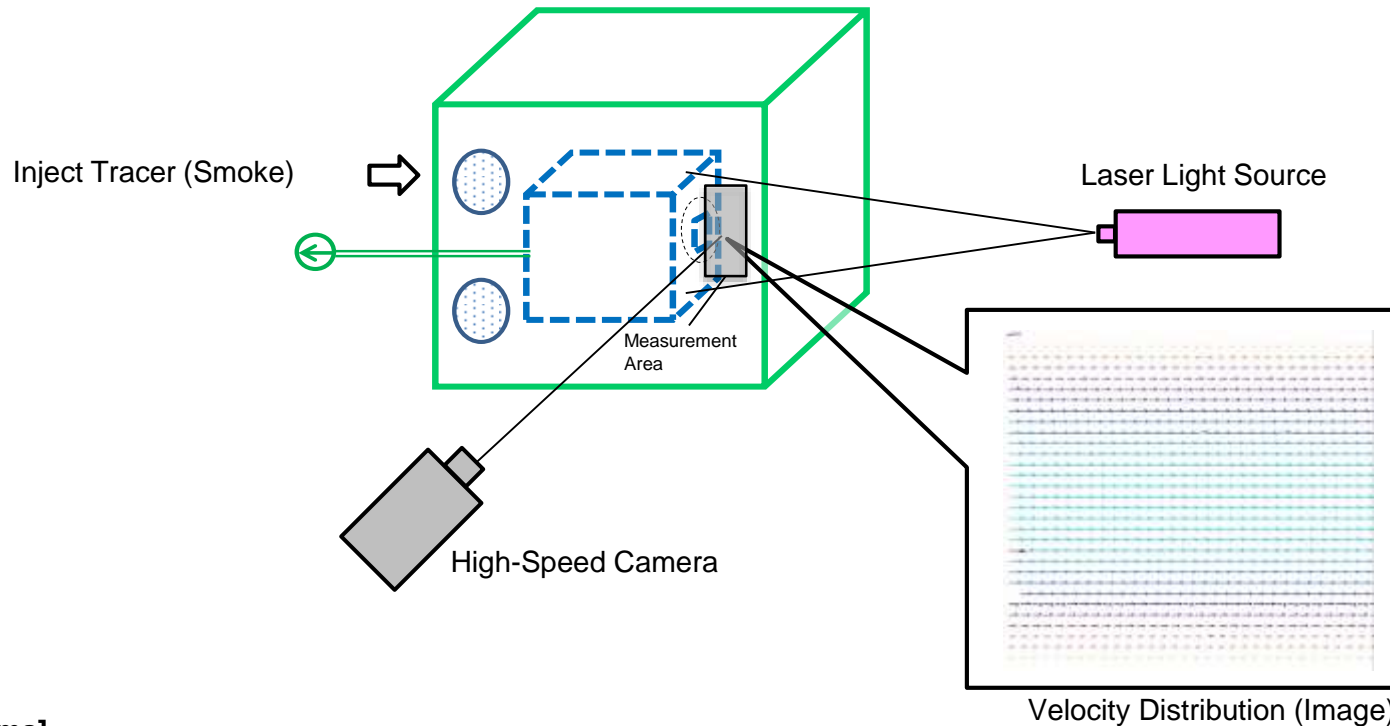

#### [Project Items]

- Maintain a negative pressure (-300 Pa) inside the primary vessel, shoot near the area simulating damage with a high-speed cinema, and compute the speed distribution (base condition).  
=> Confirm in-leak is ensured (no outer leak).  
=> (Used as the verification data for airflow analysis.)
- Change the pressure in the primary vessel between -300 and -50 Pa gradually and measure the speed distribution accordingly.  
=> Identify the pressure (differential pressure between inside and outside of the primary vessel) sufficient to ensure in-leak.
- Change the size of the simulated damage and measure the speed distribution accordingly.

# VI. Implementation Details

(1) (i) Technical Development for Ensuring Confinement Function

(b) Element Test for Differential Pressure Control

## 5) Items to be Simulated in Element Test

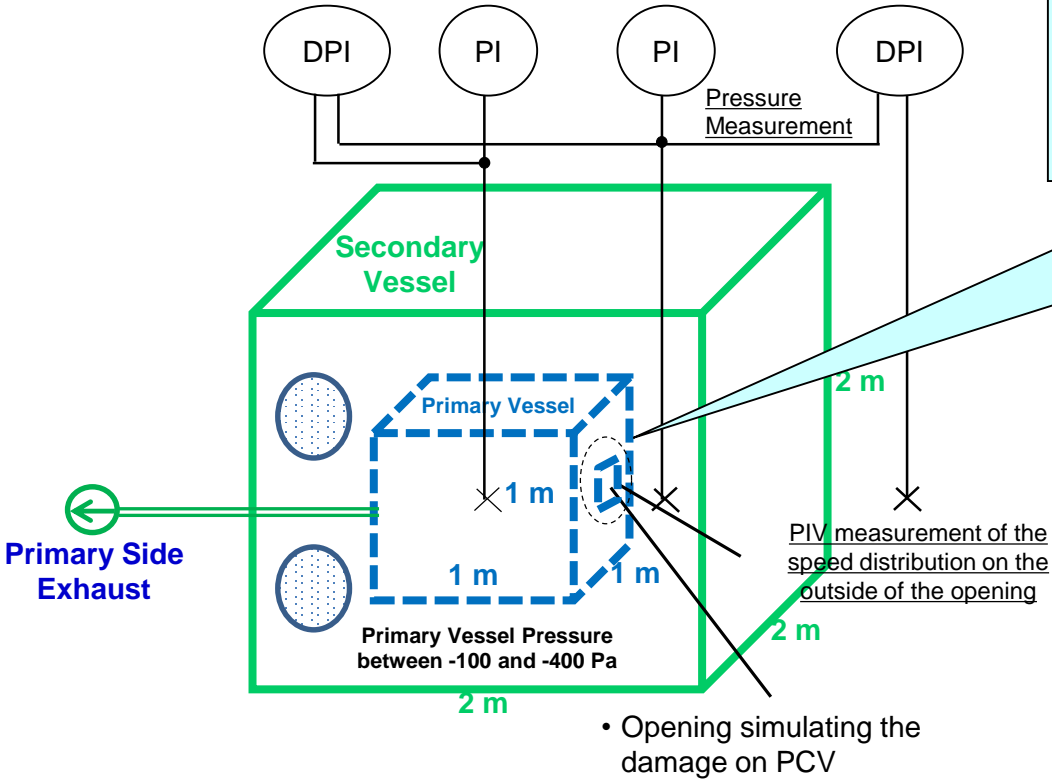

**Simulate the profile of the damage opening expected on the actual installation in a reduced size**

- PCV head flange (leak in a circumferential direction)
- Cable penetration (annular channel), etc.
- Combination of upper section (PCV head) and side (penetration portion) openings

=> Do these have an impact on the flow field of the primary vessel?

**Test Results**

- Determine the limit differential pressure corresponding to expected profiles of damage openings
- Correlation between exhaust volume W and differential pressure  $\Delta P$  ( $\Delta P \propto W^2$ )
- The coefficients of the above correlation equation changes as the profile and area of a damage opening change

=> Reflected in the damage opening model for airflow analysis

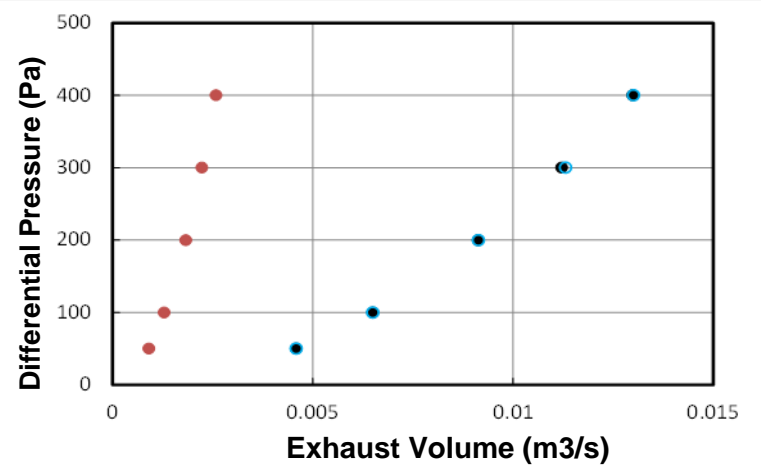

# VI. Implementation Details

## (1) (i) Technical Development for Ensuring Confinement Function

### (c) Test to Estimate the Area of Opening in Actual PCV

1) Proposal for Testing the Amount of Nitrogen to Fill and Increase or Decrease of Exhaust Flow Rate in Order to Estimate the Area of Opening in Actual PCV

#### <Test Purpose>

To review the procedures to estimate the area of opening in the PCV that forms a primary boundary, determine the required airflow rate for maintaining a constant negative pressure in the primary boundary (= airflow rate required in the gas control system), and make on-site measurements. [Adjustment operation within a range where the current control conditions (i.e. a weak positive pressure state to keep the inert state of the PCV) ]

Estimate the resistance coefficient at the opening by changing the flow rate of both the nitrogen filling system supplying nitrogen to the PCV (RPV) and the PCV gas control system for exhaust from the PCV and measuring changes in the differential pressure between inside and outside of the PCV to estimate the area of opening.

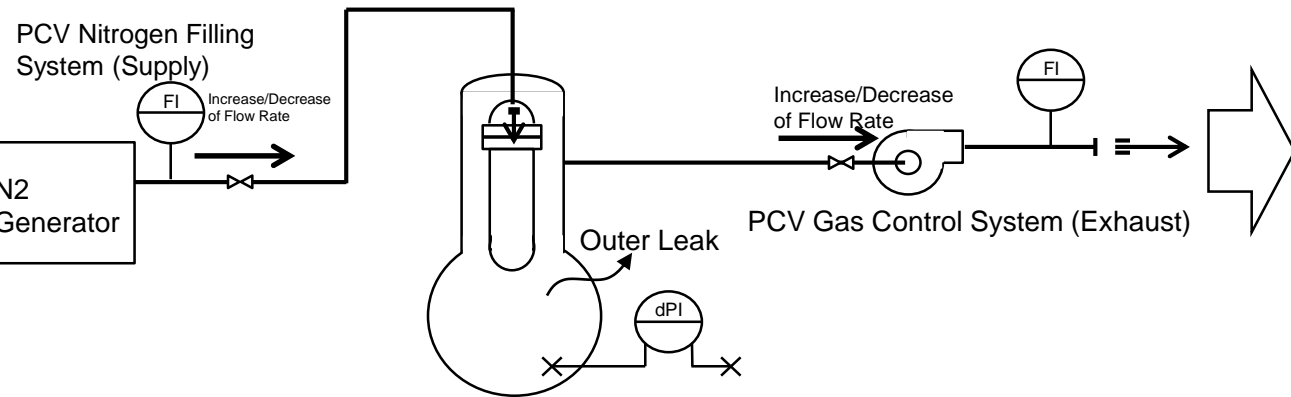

Differential Pressure Measurement While Changing Air Supply and Exhaust Volumes

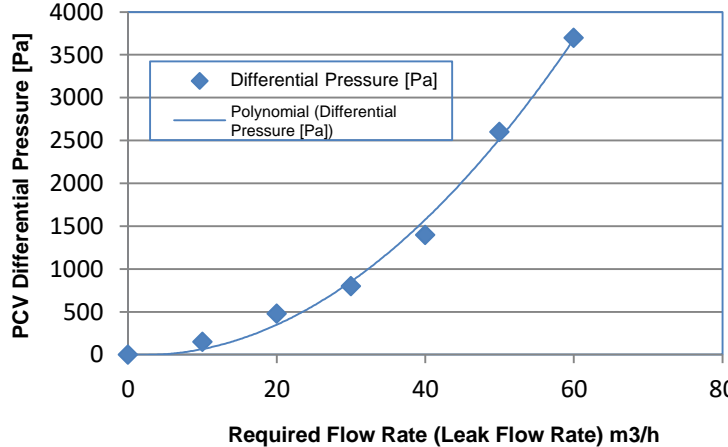

PCV Differential Pressure and Required Flow Rate with Openings in PCV (Image)



## VI. Implementation Details

(1) (i) Technical Development for Ensuring Confinement Function

(c) Test to Estimate the Area of Opening in Actual PCV

2) Preparation Items for Testing the Amount of Nitrogen to Fill and the Change of Exhaust Flow Rate in Order to Estimate the Opening Area in Actual PCV (Under Consideration)

(i) Proposed Test Overview (As Described in Previous Two Pages + This Page)

a) **Test to Estimate the Amount of System In-Leak**

Estimate the amount of leak in the PCV gas control system and N2 filling system by changing the supply and exhaust flow rates while maintaining the PCV pressure at a constant target value.

When the PCV pressure is constant, the amount of leak is the same for PCV and parts at the same pressure level. Compute changes in the flow rate difference between supply and exhaust as the leak in the PCV gas control system or N2 filling system.

b) **Test to Estimate the Area of Opening in PCV**

Change the PCV pressure by changing the supply and exhaust flow rates, calculate the amount of leak from the PCV, and estimate the area of opening (the value determined here is equivalent to the "Area \* Resistance Coefficient" of the opening). [Example - Unit 1: About the same size as an orifice with a size of 10 mm in diameter (Operation Database as of January 22, 2018)]

(ii) **Confirming System Specifications for the Actual Installation** <TEPCO HD>

Confirm the exhauster specifications, pressure, and flowmeter accuracy (including the availability of temperature/pressure calibration).

(iii) **Studying System Specifications Required for Testing** <TEPCO HD>

Evaluate the accuracy of the flow rate change width, pressure indicator, and flowmeter required for the tests mentioned in a) and b) above, confirm the applicability of current facilities, and propose plans to modify the actual installation as necessary.

(iv) **Conducting Tests and Organizing Test Results** <TEPCO HD>

# VI. Implementation Details

## (1) (i) Technical Development for Ensuring Confinement Function

### (d) Reviewing Measures to Improve Sealability

Conceptual proposals for the container structure were reviewed to improve sealability during fuel debris retrieval.

- All-Encompassing Container: Covers the entire existing facilities
- Individual Container: Each covers a fuel debris retrieval cell only
- SSC (Single Skin Container): Container walls are built with onefold panels
- WSC (Double Skin Container): Container walls are built with twofold panels

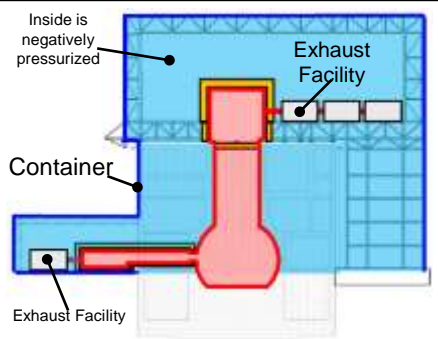
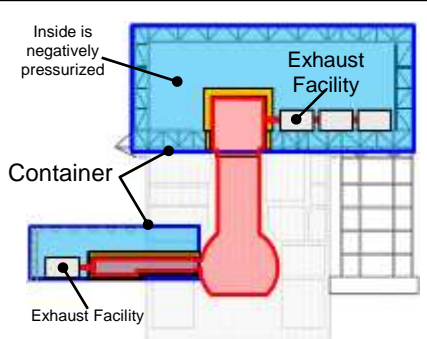
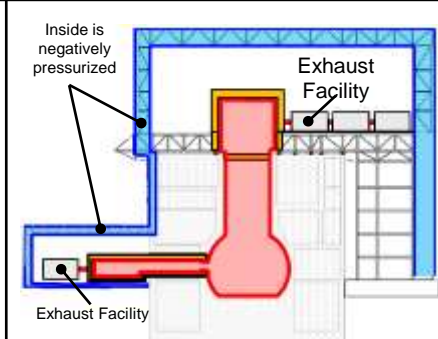
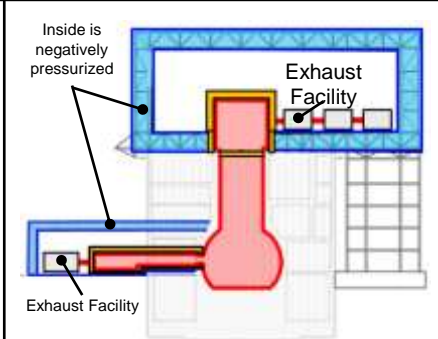
	All-Encompassing Container SSC	Individual Container SSC	All-Encompassing Container WSC	Individual Container WSC
Proposed Structure	 <ul style="list-style-type: none"> <li>• Covers the entirety of the fuel debris retrieval cells and their ancillary facilities. (Imagine a full-scale container.)</li> <li>• Can be built without applying load on the building.</li> </ul>	 <ul style="list-style-type: none"> <li>• Covers the fuel debris retrieval cells individually for retrieval from the top and the side.</li> <li>• Additionally requires sufficient building structure strength and installation of a mount.</li> </ul>	 <ul style="list-style-type: none"> <li>• Covers the entirety of the fuel debris retrieval cells and their ancillary facilities.</li> <li>• This proposed structure was adopted in Chernobyl.</li> <li>• Can be built without applying load on the building.</li> </ul>	 <ul style="list-style-type: none"> <li>• Covers the fuel debris retrieval cells individually for retrieval from the top and the side.</li> <li>• Additionally requires sufficient building structure strength and installation of a mount.</li> </ul>
Confinement	The inner space enclosed in the container is negatively pressurized and confined.	Each fuel debris retrieval cell is enclosed individually in a container and confined through negative pressurization.	The inside of the container is negative pressurized and confined.	The inside of the container is negative pressurized and confined.

## VI. Implementation Details

### (1) (i) Technical Development for Ensuring Confinement Function

[Summary]

#### (a) Analyzing Negative Pressure, Airflow Distribution, etc. in Each Boundary

- In FY 2017, in order to ensure the confinement function, a verification method was selected that combines analyses and tests and an analysis code for verification, analysis conditions were reviewed, and a trial analysis was conducted.
- In FY 2018, analyses on the negative pressure and airflow in each boundary (entire area) will be conducted.

#### (b) Element Test for Differential Pressure Control

- In FY 2017, items to be confirmed in an element test were reviewed. [Reviewed simultaneously with Item (a)]
- In FY 2018, the element test will be conducted and the limit differential pressure evaluated.

#### (c) Test to Estimate the Area of Opening in Actual PCV

- In FY 2017, the concept of test methods were reviewed.
- In FY 2018, test methods will be further reviewed and a proposal to TEPCO HD submitted.

#### (d) Reviewing Measures to Improve Sealability

- In FY 2017, conceptual proposals for the container structure were reviewed.
- In FY 2018, measures to improve the sealability of the container structure and its ancillary facilities will be reviewed.

## VI. Implementation Details

### (2) Technical Development for Dust Collection/Removal Derived from Fuel Debris

[Objectives]

To select advantage technologies for retrieving fuel debris, obtain data, and review systems.

#### End of FY 2017: Select Effective Model and Review Systems

Technical Investigation: Create technology mapping and evaluate technologies to identify better ones

Element Test: Develop a test plan

System Study: Study on the systems based on results of technology investigation

#### End of FY 2018: Obtain Data and Review Systems

Technology Investigation: None (Additional investigation will be conducted as necessary)

Element Test: Conduct a test

System Study: System study based on result of elemental test

## VI. Implementation Details

### (2) Technical Development for Dust Collection/Removal Derived from Fuel Debris

#### (i) Technical Development for Reducing and Removing Radioactive Materials in Gas Phase System

#### 1) Gas System Overview

- The (proposed) configurations for the gas phase particle capture and removal facility are as follows:
  - As the particle capture portion of the gas phase particle capture and removal facility takes final performance credit for the gas system in terms of performance and results, a high efficiency particle filter (HEPA filter) should be installed at the final stage. However, there is a concern that this filter may need to be replaced frequently due to clogging.
  - To protect the high efficiency particle filter and reduce the frequency of replacement, a pretreatment system should be installed to provide coarser filtering of particles before the final treatment.

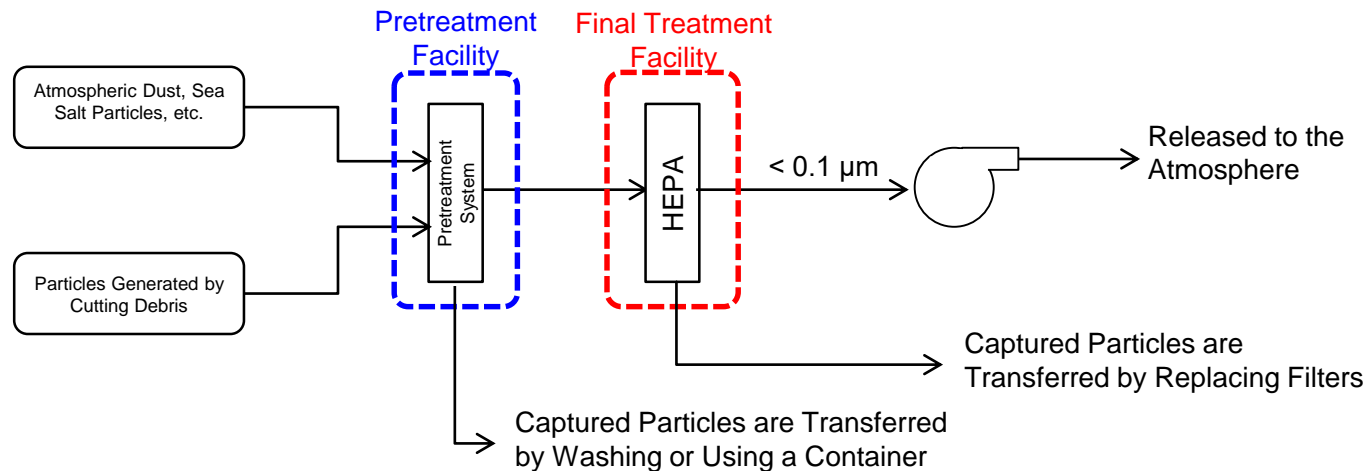

Figure - (Proposed) Configurations for the Gas Phase Particle Capture and Removal Facility

The pretreatment and final treatment are defined as follows:

- Pretreatment: Larger particles up to  $1\ \mu\text{m}$  (tentative definition, revised in response to treatment methods)
- Final Treatment: Captures particles with the size of approximately  $0.1\ \mu\text{m}$

# VI. Implementation Details

## (2) Technical Development for Dust Collection/Removal Derived from Fuel Debris

### (i) Technical Development for Reducing and Removing Radioactive Materials in Gas Phase System

## 2) Technology Benchmarking (Selecting Advantage Technologies)

Based on the results of the technical study, technologies which did not meet the system conditions in terms of the throughput and performance were excluded, and the remaining equipment, based on similar principles, was further narrowed down by comparing their removal performance, amount of waste, and maintenance etc. to select advantage technologies.

<Reasons for Selecting Multiple Models>

- As the system's entry conditions (e.g. the diameter and amount of particles, pH, and the presence/absence of boric acid) of the actual installation entail a great deal of uncertainties, technologies with different features were selected so that changes in these conditions can supported.
- In this project, although a single system configuration was set up to review the layout, alternative rearrangement plans in response to the conditions of the actual installation were also considered.

Table - Gas Phase Particle Capture and Removal Facilities (Selected Advantage Technologies)

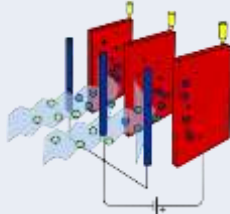
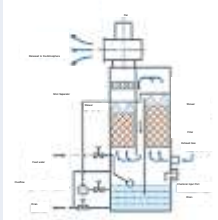
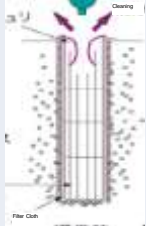
[Pretreatment System]				
Model	Centrifugal Dust Collection	Electric Dust Collection	Wet Dust Collection	Filter Dust Collection
Principles and Features	A cyclone-type dust collector. Captures particles more efficiently than conventional cyclone structures by attenuating the drag acting on particles.	Captures particles by giving an electric charge to various particles contained in the dust air and drawing them to collecting electrodes.	Captures particles in water by running particles through an underwater filler.	Filters particles contained in dusty gas with layers of particles adhered and deposited on the surface of and inside filter cloths.
Schematic Drawing				
Advantages in Application to 1F	The removal capability is relatively low. Produces minimal waste (no consumables and liquid waste), small, and has a wide range of application.	The removal capability is relatively high. However, restrictions of this model include the need to confirm the electrostatic propensity of particles and take measures against moisture (to prevent sparks).	Insufficient data is available about its removal capability (for particles). Has an exclusive advantage that other models do not have - capable of removing gas components if necessary.	Superior in terms of the removal capability, range of application, and proven record of performance, but produces waste. Used to extract organic elements for which this model has an extensive proven record of performance and metallic elements to reduce waste.

[Supplemental Information] A high reliability filter dust collection model was selected to ensure wide availability for use and a sufficient removal capability. In addition, as the filter dust collection model produces filter waste, a filterless model was also selected.

## VI. Implementation Details



(2) Technical Development for Dust Collection/Removal Derived from Fuel Debris

(i) Technical Development for Reducing and Removing Radioactive Materials in Gas Phase System

2) Technology Benchmarking (Selecting Advantage Technologies)

Table - Gas Phase Particle Capture and Removal Facilities (Selected Advantage Technologies)

[Final treatment System]

Model	HEPA (Glass Fiber)	HEPA (Metal)	ULPA (Glass Fiber)
Principles and Features	Filters particles contained in a portion of air with layers of particles adhered and deposited on the surface of and inside filter cloths.	Removes particles in the gas phase with filters with adjusted pore sizes.	Filters particles contained in a portion of air with layers of particles adhered and deposited on the surface of and inside filter cloths.
Schematic Drawing			
Advantages in Application to 1F	<u>Can support the target removal performance (DF =10<sup>5</sup>). Has a permitted and authorized record of performance.</u>	This model's removal performance is equivalent to that of glass fiber filters. Although this model does not have a permitted and authorized record of performance, <u>it has an advantage in terms of the amount of waste and environmental applicability.</u>	Superior in terms of the removal performance. (When compared to HEPA, the single-item performance of ULPA is higher by approximately 2 orders of magnitude.) <u>Considered an option in the case where a higher level of removal performance is required than that currently available.</u>

[Supplemental Information] Dust collection methods based on the principle of filtration were selected, because it is necessary to guarantee a high removal capability regardless of the particle size in treating exhaust emitted to the environment. In addition to HEPA (glass fiber) with an extensive proven record of performance, two models were selected in consideration for supporting changes in the entry conditions and requirements.

## VI. Implementation Details

### (2) Technical Development for Dust Collection/Removal Derived from Fuel Debris

#### (i) Technical Development for Reducing and Removing Radioactive Materials in Gas Phase System

### 3) Necessity for Element Test

Items to Be Confirmed in the Test	Model	Necessity for Element Test	Items to Be Confirmed in the Test (Data Acquired/Criteria) * Shown in red are where each item is reflected
Removal Performance	Centrifugal Dust Collection	Insufficient data is available about its removal performance for particles with a higher specific gravity including UO <sub>2</sub> .	Removal performance for simulated particles => Exposure Assessment
	Wet Dust Collection	Insufficient data is available about its removal capability for particles because this model is generally used for removing gas components.	Removal performance for simulated particles => Exposure Assessment
	Filter Dust Collection Electric Dust Collection	- (Can be designed once the entry conditions are in place.)	
Backwash Performance	Filter Dust Collection (Filter Material: Metal)	Insufficient performance data is available about its dependency on the particle size and humidity.	Differential pressure recovery performance for simulated particles and environmental conditions => Evaluation of the Frequency (or Necessity) of Replacement
	Filter Dust Collection (Filter Material: Glass Fiber/Organic Fiber, Non-Metal Materials)	- (An extensive proven record of performance data is available about its dependency on the particle size and humidity.)	
Remote Replacement Technology (Particle Collection Container)	Common to All Models (Not Needed for Models that Collect Particles as Liquid Waste)	Generally, when containers need to be replaced while suppressing dispersion, human intervention or large-scale equipment (e.g. within a plant) is used. Therefore, it is necessary to develop a technology for replacing collection containers of the gas system.	Replaceability. Ensured sealability after replacement. => Maintenance Policy and Component Layout
Remote Replacement Technology (Filter)	Common to All Square Filters	No proven performance record is available for any technologies capable of remote replacement of square filters while ensuring the sealability and seismic resistance. Therefore, a new technology needs to be developed.	Replaceability. Ensured sealability after replacement. => Maintenance Policy and Component Layout
	Common to All Cylinder Filters (Replaced in the Horizontal Direction)	The technology for replacing filters in the vertical direction is large-scale (10 m or higher) and largely restricted in terms of the layout (e.g. hard to be installed inside R/B). Therefore, in consideration of the layout feasibility, the need is high for equipment that is small and can support replacement in the horizontal direction.	Replaceability. Ensured sealability after replacement. => Maintenance Policy and Component Layout
	Common to All Cylinder Filters (Replaced in the Vertical Direction)	- (This technology is used in Rokkasho and retreatment facilities in the US and UK.)	

=> An element test is being prepared for acquiring data missing from the "Necessity for Element Test."



## VI. Implementation Details

(2) Technical Development for Dust Collection/Removal Derived from Fuel Debris

(i) Technical Development for Reducing and Removing Radioactive Materials in Gas Phase System

### 4) Test Conditions

The table below shows major test conditions and the concept behind them.

Type	Item	Test Conditions	Concepts	Notes
Simulated Particles	Particle Size	(Pretreatment) 0.1, 1, and 4 $\mu\text{m}$ [Tentative]	The following evaluation results are considered: the particle distribution in laser processing (between 0.1 and a few $\mu\text{m}$ ) and machining (a few $\mu\text{m}$ or larger), and the maximum particle size associated with the gas.	<ul style="list-style-type: none"> <li>Specified based on the particle size distribution during processing obtained by now.</li> <li>Multiple particle sizes were tested in a single particle size test to confirm the degree of performance dependency on the particle size.</li> <li>Characteristics were obtained as a reference when particles of multiple sizes flow simultaneously. (Expected effects include improvement of the removal performance by captured particles.)</li> </ul>
		(Final Treatment) 0.1, 1 $\mu\text{m}$ [Tentative]	If the pretreatment can remove particles with a size of a few $\mu\text{m}$ and larger, refining the conditions will also be considered.	
	Specific Gravity	Tungsten Dioxide (11) SUS316L (8) Silica Sand (2.6–2.7)	Equivalent to Fuel (UO <sub>2</sub> ) (11) Equivalent to Structure (Stainless) (8) Equivalent to Concrete (2 to 3)	<ul style="list-style-type: none"> <li>Tests were conducted under multiple conditions by referring to the specific gravity of estimated materials that comprised the fuel debris. Data was acquired on the degree of dependency on the specific gravity.</li> </ul>
Process Conditions	Flow Rate	(Equipment Dependent on the Flow Rate)  100, 500, 1000, and 2000 m <sup>3</sup> /h	The following are included in the conditions: 100 m <sup>3</sup> /h: Equivalent to the estimated amount of in-leak at the opening of the actual installation of Unit 1 + the minimum amount of nitrogen to fill. 2000 m <sup>3</sup> /h: Conditions reviewed last year.	<ul style="list-style-type: none"> <li>Although no cleaning target is in place and conditions are not fixed on the system side, conditions were set based on the concept shown to the left.</li> </ul> (Even when the flow rate falls outside these conditions, adjustments can be made based on the number (area) of elements except for the centrifugal method. The centrifugal method requires an estimation based on the test and existing data.)
Gas Composition	Humidity	(Pretreatment) Up to 100%	In pretreatment, the assumption is that humidity adjustment is not performed due to possible inflow of flammable gas.	<ul style="list-style-type: none"> <li>For items on which humidity is expected to have less impact, tests will be conducted under two humidity conditions for confirmation. (For similar methods, however, the rationalization of test cases is being considered by, for example, selecting and testing only one model as a representative case.)</li> </ul>
		(Post-Treatment) -	In the post-treatment, the assumption is that the humidity can be adjusted through temperature adjustment because target fluids have already been treated in the pretreatment.	<ul style="list-style-type: none"> <li>In order to widen the range of operating conditions, considerations are being made to determine whether tests should be conducted using multiple humidity conditions.</li> </ul>

# VI. Implementation Details

## (2) Technical Development for Dust Collection/Removal Derived from Fuel Debris

### (ii) Technical Development for Reducing and Removing Radioactive Materials in Liquid Phase System

#### 1) Liquid System Overview

● The (proposed) configurations for a new circulation cooling facility are as follows: The facility should have a capability to process at 3 m<sup>3</sup>/h equivalent to the current rate of water injection to the reactor with a baseline circulation flow rate of 10 m<sup>3</sup>/h.

(i) Insoluble α Nuclides Removal Facility

Composed of up to three types of removal equipment (e.g. filters).

(ii) Soluble Nuclides Removal Facility

As a subsequent stage following the insoluble nuclide removal, composed of equipment (adsorption vessel) for removing soluble nuclides.

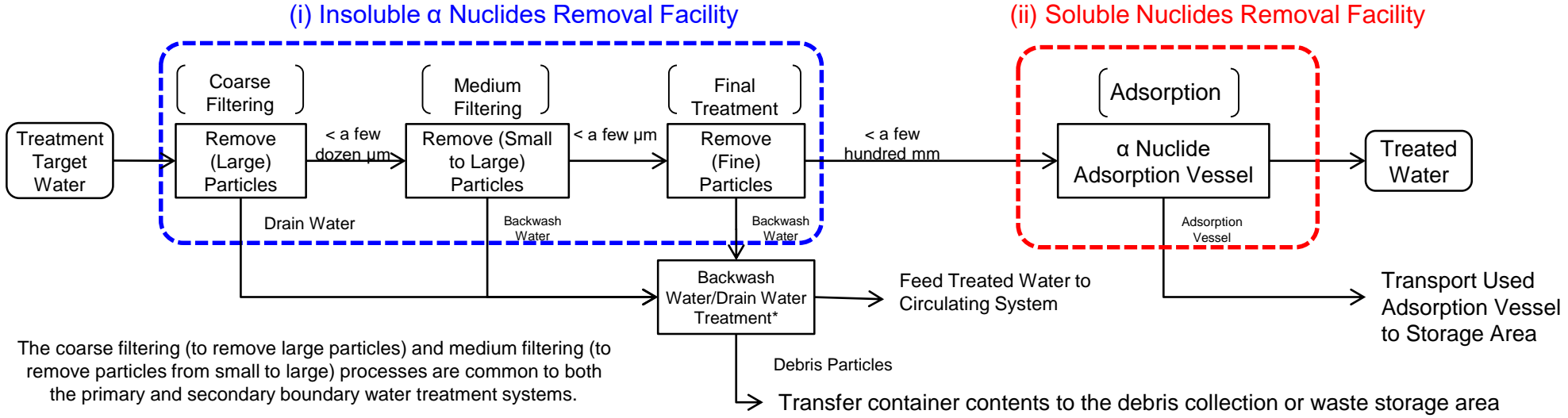

The coarse filtering (to remove large particles) and medium filtering (to remove particles from small to large) processes are common to both the primary and secondary boundary water treatment systems.

Coarse filtering, medium filtering, and final treatment are defined as follows:  
 A) Coarse Filtering: Captures particles with a size of a few dozen μm  
 B) Medium Filtering: Captures particles with a size of a few μm  
 C) Final Treatment: Captures particles with a size of 0.1 μm or so

Figure - (Proposed) Configurations for Circulation Cooling Cleaning Facility

\* The drain water and backwash water are treated in a separate facility as they are not drained continuously.

# VI. Implementation Details

- (2) Technical Development for Dust Collection/Removal Derived from Fuel Debris
  - (ii) Technical Development for Reducing and Removing Radioactive Materials in Liquid Phase System

## 1) Liquid System Overview (Facilities Under Review)

- The review items required for realizing a liquid system that meets the safety requirements are as follows:
  - (i) Suppressing Radioactive Emission (Capturing Insoluble  $\alpha$  and Soluble Nuclides)
  - (ii) Collecting Captured Particle Nuclides
  - (iii) Collecting Waste (e.g. Filters)
  - (iv) Reducing Waste
- The table below lists facilities under review for each issue:

Table - Issues for Realizing the System that Meets the Safety Requirements and Facilities Under Review

Issues Relating to the System Feasibility		Facilities Under Review		
		Circulation Cooling Facility		Contaminated Water Treatment Facility
		Insoluble $\alpha$ Nuclides Removal Facility	Soluble Nuclides Removal Facility	
(i)	Suppressing Radioactive Emission	Reviewed	Reviewed	Reviewed
(ii)	Collecting Captured Particle Nuclides	Reviewed	-	-
(iii)	Collecting Waste (e.g. Filters)	Reviewed	Reviewed	-
(iv)	Reducing Waste	Reviewed	Reviewed	Reviewed

## VI. Implementation Details

(2) Technical Development for Dust Collection/Removal Derived from Fuel Debris





(ii) Technical Development for Reducing and Removing Radioactive Materials in Liquid Phase System

### 2) Technology Benchmarking (Selecting Advantage Technologies)

Based on the technical study results, technologies which did not meet the system conditions in terms of throughput and performance were excluded, and the remaining equipment, based on similar principles, was further narrowed down by comparing removal performance, amount of waste, maintenance, etc., to select advantage technologies.

\* The reasons for selecting multiple models are the same as those for the gas phase system. (See page 44)

Table - Liquid Phase Particle Capture and Removal Facilities (Selected Advantage Technologies) **[Insoluble (Particle) Nuclides Removal (Coarse/Medium Removal)]**

Application	Coarse Filtering		Medium Filtering	
Model	Liquid Cyclone	Auto Strainer	High-Capacity Filter (e.g. Bag Filters)	Large Pore Microfiltration (MF Membrane) Filter
Principles and Features	Separates particles with higher specific gravity by applying centrifugal force to the water flow.	Removes particles by passing the water through the screen. The filter can be automatically cleaned with swirl flows.	The water is poured into the tubular inside of the filter unit to move solid materials to the inside and the liquid to the outside.	Separates particles from water by letting the water through fine pores. Backwashable due to its higher physical strength.
Schematic Drawing				
Advantages in Application to 1F	Separation of particles by centrifugal force is <u>effective for removing debris particles with higher specific gravity.</u>	Larger size particles can be surely separated by the strainer <u>in addition to the centrifugal force.</u> Also, it is <u>small and has a simple mechanism and high maintainability.</u>	The particles with a relatively larger size can be surely removed by <u>selecting the filter pore size.</u> Plenty of particles can be collected.	The particles with a relatively larger size can be surely removed by <u>selecting the filter pore size.</u> Waste reduction can be expected by <u>backwashing.</u>

[Supplemental Information] Since coarse filtering is intended to reduce waste at the pre-stage of filtering and membrane dust collection by removing larger size particles (a few dozen μm or larger), two filterless centrifugal models with lower application risks were selected.

Medium filtering is intended to surely remove relatively large sized particles (a few μm or larger) at the pre-stage of membrane dust collection, adjust operating conditions of membranes, and reduce waste.

Two filtering models were selected by taking into account the required functions and applicability.

# VI. Implementation Details

- (2) Technical Development for Dust Collection/Removal Derived from Fuel Debris
  - (ii) Technical Development for Reducing and Removing Radioactive Materials in Liquid Phase System
- 2) Technology Benchmarking (Selecting Advantage Technologies)

Table - Liquid Phase Particle Capture and Removal Facilities (Selected Better Technology)  
**[Insoluble (Particle) Nuclides Removal (Final Treatment)]**

Application	Final Treatment	
Model	MF Membrane	UF Membrane
Principles and Features	Separates particles from water by letting the water through fine pores. Backwashable due to its higher physical strength.	
Schematic Drawing		
Advantages in Application to 1F	Removable minimum particle size is larger than UF membranes, but <u>the blockage risk is relatively low.</u>	<u>Removable minimum particle size is smaller than MF membranes,</u> but the blockage risk is relatively high.

[Supplemental Information] As a model to surely remove particles with a size of 0.1µm or larger which is required for preventing the blockage of the adsorption vessel to remove soluble nuclides (i.e. increased replacement frequency), two successful principles (models) including in the general industries were additionally chosen.

# VI. Implementation Details

- (2) Technical Development for Dust Collection/Removal Derived from Fuel Debris
  - (ii) Technical Development for Reducing and Removing Radioactive Materials in Liquid Phase System
- 2) Technology Benchmarking (Selecting Advantage Technologies)

Table - Liquid Phase Particle Capture and Removal Facilities (Selected Better Technology) [Insoluble Nuclides Removal]

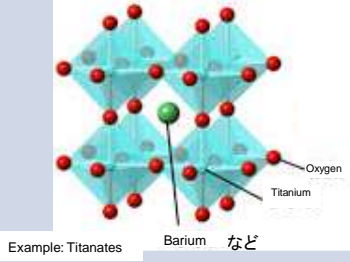
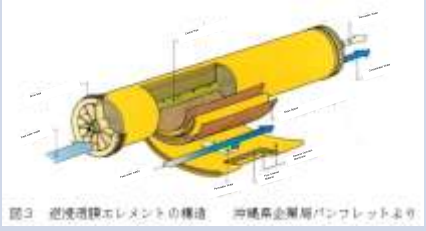
Model	Adsorption Vessel (Organic Base Material)	Adsorption Vessel (Inorganic Base Material)	Reverse Osmosis Membrane (including Nanomembrane)
Schematic Drawing			
Advantages in Application to 1F	<p>Ion exchange resins are <u>not selective of adsorbed ions, but can remove various ions simultaneously</u>. Tannic acid compounds are <u>known to adsorb actinide elements</u>. However, not a lot has been known about them under coexistence with highly concentrated boric acids, so additional confirm ation is required with a test.</p>	<p>They are <u>known to adsorb actinide elements such as oxine-impregnated activated charcoal, zeolites, titanate compounds, and titanium silicate compounds</u>. However, not a lot has been known about them under coexistence with highly concentrated boric acids, so additional confirm ation is required with a test.</p>	<p>Reverse osmosis membranes are <u>known to be able to block almost all ions</u>. Similarly, nanomembranes are <u>known to be able to block a lot of multivalent ions</u>. However, since both of these membranes generate concentrated water containing collected ions, it is necessary to consider how to treat the concentrated water before adopting them.</p>

[Supplemental Information] Based on the performance of removing soluble radioactive materials contained in liquid waste to a level of concentration restricted in public notifications and a proven record of application in 1F, two principles (3 models), namely, adsorption vessels (organic/inorganic base materials) and reverse osmosis membrane were selected.

## VI. Implementation Details

(2) Technical Development for Dust Collection/Removal Derived from Fuel Debris

(ii) Technical Development for Reducing and Removing Radioactive Materials in Liquid Phase System

### 3) Necessity of Element Test (Overall)

Type	Items to Be Confirmed in the Test	Model	Necessity for Element Test	Items to Be Confirmed in the Test (Data Acquired/Criteria) * Shown in red are where each item is reflected
Insoluble Nuclides Removal	Removal Performance	Liquid Cyclone Auto Strainer	Insufficient data is available about its removal performance for particles with a higher specific gravity including UO <sub>2</sub> .	Removal performance for simulated particles => Exposure Assessment
		Filter Dust Collection (Filter, Membrane)	- (Can be designed once the entry conditions are in place.)	
	Information about Waste	Drain Water Properties (Liquid Cyclone, Auto Strainer)	Insufficient data is available about the properties of drain water corresponding to expected specific gravities and particle sizes.	Drain water properties for simulated particles and environmental conditions => Review Drain Water Treatment Facilities
		Backwash Performance and Backwash Water Properties (Sintered Metal Filter, MF Membrane, and UF Membrane)	Insufficient data is available about the backwash performance and the properties of drain water corresponding to expected specific gravities and particle sizes.	Differential pressure recovery performance for simulated particles and environmental conditions  => Evaluate the Replacement Frequency (Necessity) and Review Backwash Water Treatment Facilities
Soluble Nuclides Removal	Removal Performance	Adsorption Vessel (Adsorbing Material)	Insufficient data is available about its removal performance for expected nuclides and operating environment.  The impacts of sodium pentaborate are hard to evaluate.	Removal performance for simulated liquid waste (Because some nuclides including Pu are hard to be obtained within the available period of time, they are evaluated based on literature research.) => Capacity of Facility, Equipment Layout
	Information about Waste	Adsorption Vessel (Adsorbing Material)	Insufficient data is available about its (limit) removal performance for expected nuclides and operating environment.  The impacts of sodium pentaborate are hard to evaluate.	The amount of water that can be conveyed for simulated liquid waste (Because some nuclides including Pu are hard to be obtained within the available period of time, they are evaluated based on literature research.) => Amount of Waste Generated, Maintenance Policy

=> An element test is being prepared for acquiring data missing from the “Necessity for Element Test.”

## VI. Implementation Details

(2) Technical Development for Dust Collection/Removal Derived from Fuel Debris

(ii) Technical Development for Reducing and Removing Radioactive Materials in Liquid Phase System

3) Necessity for Element Test (in Existing Contaminated Water Treatment Facility)

- After the liquid system is constructed, it is necessary to ensure a certain level of nuclides removal performance and suppress the amount of waste generated to the current level or lower in the existing water treatment facility.
- In the existing water treatment facility, it is required to treat the water added from outside into the circulation cooling system such as groundwater flowing into the reactor building.
- Sodium pentaborate may be contained in the cooling water for preventing re-criticality during a debris retrieval process. If this is the case, the Corrosion Control PJ (active until FY 2016) was made aware that the treatment performance at the existing water treatment facility might be affected, and the amount of waste generated might be increased.
- When treatment processes in the existing facility are affected, it may be required to take measures against the discharged water when it is drained from the circulation cooling system. To clarify the conditions of acceptance in the existing facility, tests are conducted on a range of matters for which data had not been acquired until last year.

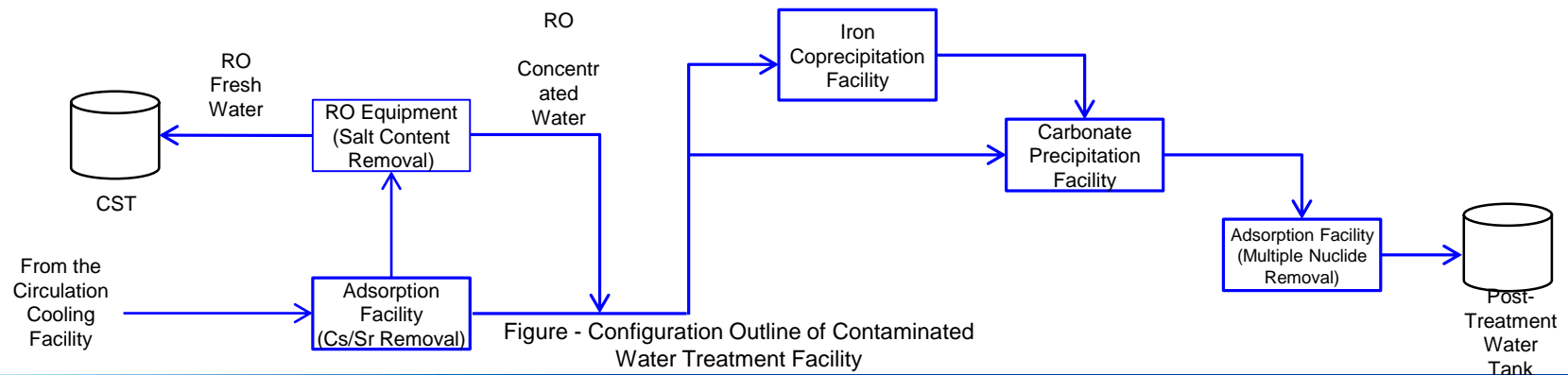



## (2) Technical Development for Dust Collection/Removal Derived from Fuel Debris

### (ii) Technical Development for Reducing and Removing Radioactive Materials in Liquid Phase System

#### 4) Test Conditions

The table below shows major test conditions and the concept behind them.

Type	Item	Test Conditions	Concepts	Notes
Simulated Particles	Particle Size	(Coarse Filtering) 10 µm and 100–200 µm [Tentative]	The following evaluation results are considered: the particle distribution in laser processing (between 0.1 and a few µm) and machining (a few µm or larger), and the maximum particle size associated with the gas.	<ul style="list-style-type: none"> <li>* Need to align with Fundamental Technology Project.</li> <li>• Specified based on the particle size distribution during processing obtained by now.</li> <li>• Multiple particle sizes were tested in a single particle size test to confirm the degree of performance dependency on the particle size.</li> <li>• Characteristics were obtained as a reference when particles of multiple sizes flow simultaneously. (Expected effects include improvement of the removal performance by captured particles.)</li> <li>• Since effective removal (separation) of particles with a size of a few µm or smaller cannot be expected with a coarse filtering facility, it is excluded from the test conditions.</li> </ul>
		(Medium Filtering) 0.1, 5, and 10 µm [Tentative]	If the coarse filtering step can remove particles of a certain size and larger, refining the conditions will be considered.	
		(Final Treatment) 0.1, 1 µm [Tentative]	If the coarse and medium filtering steps can remove particles of a certain size and larger, refining the conditions will be considered.	
	Specific Gravity	Tungsten Dioxide (11) SUS316L (8) Silica Sand (2.6–2.7)	Equivalent to Fuel (UO <sub>2</sub> ) (11) Equivalent to Structure (Stainless) (8) Equivalent to Concrete (2 to 3)	<ul style="list-style-type: none"> <li>• Tests were conducted under multiple conditions by referring to the specific gravity of estimated materials that comprised the fuel debris. Data was acquired on the degree of dependency on the specific gravity.</li> </ul>
Process Conditions	Flow Rate	(Equipment Dependent on the Flow Rate) 3, 10, and 20 m <sup>3</sup> /h	The following are included in the conditions: 3 m <sup>3</sup> /h: A flow rate confirmed to be sufficient in terms of cooling. 20 m <sup>3</sup> /h: A sufficient flow rate for replacing the holding water quantity in about a month (two weeks if D/W is used) in the case of flooding.	<ul style="list-style-type: none"> <li>• Although no cleaning target is in place and conditions are not fixed on the system side, conditions were set based on the concept shown to the left. (Even when the flow rate falls outside these conditions, adjustments can be made based on the number (area) of elements except for the centrifugal method. The centrifugal method requires an estimation based on the test and existing data.)</li> </ul>
Liquidity	pH	Neutral (Adjusted by using industrial water or dispersing agents, etc.)	Since this test is intended to confirm the performance against different particle sizes and specific gravities, if the particle size changes by aggregation, the use of dispersing agents, etc., will be considered (To be confirmed in a beaker test in advance.)	The behaviors of actual particles (aggregation, deposition, and dissolution) are assumed to change depending on their pH levels. This technical development is intended to obtain information enabling a performance assessment once the particle sizes and specific gravities are confirmed under the pH conditions of the actual installation. (If it is difficult to dissolve the aggregation of particles using a reasonable test method, the particle size is measured during a test directly through sampling to summarize the relationship between the particle size and equipment performance.)

# VI. Implementation Details

## (2) Technical Development for Dust Collection/Removal Derived from Fuel Debris

[Schedule]

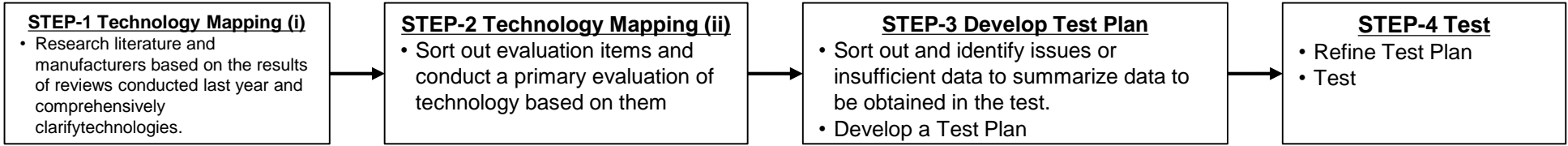

	FY 2017				FY 2018				
Item	1Q	2Q	3Q	4Q	1Q	2Q	3Q	4Q	
Master Schedule		Interim Report Meeting		End-of-Year Report Meeting		Interim Report Meeting		Final Report Meeting	
Technology Mapping (i) (Technical Investigation)	[Bar]			Results of Research on Existing Technologies					
Technology Mapping (ii) (Narrowing Down Advantage Technologies)		[Bar]		Results of Selecting Significant Technologies					
Build a Test Plan (Outline Plan)			[Bar]						
Element Test (Detailed Plan, Test)					[Bar]				Element Test Results (Equipment Performance/Layout Conditions)
Feedback to System Studys				Review of Equipment Models and Specifications and System Configurations			Review of Equipment Models and Specifications and System Configurations		

## VI. Implementation Details

### (2) Technical Development for Dust Collection/Removal Derived from Fuel Debris

#### [Summary]

- **Conducted research on the existing technologies, both inside and outside Japan, for removing dust and soluble nuclides.**
- **Reviewed the technologies' applicability in debris retrieval to select advantage technologies.**
- **Based on the selected advantage technologies, identified data to be obtained in the element test and technologies to be developed in order to study system optimization.**
- **Currently, the preparation for the element test is in progress, and FY 2018 will focus on the element test and evaluations.**

## VI. Implementation Details

### (3) Study on $\alpha$ Nuclide Monitoring System for Fuel Debris Retrieval

[Objectives]

- Target setting and system study for monitoring, and development planning as necessary

#### **End of FY 2017: System Outline Review (at a Level that Allows Feasibility Judgement)**

Technical Investigation: Create technology mapping and evaluate effective models

Set monitoring targets and detection accuracy requirements

System Study: System study for results of technology investigation

#### **End of FY 2018: System Outline Review and Development Plan Creation**

Technical Investigation: Create technology mapping and evaluate effective models

Set monitoring targets and detection accuracy requirements

System Study: System study for results of technology investigation

\* Development plans are created for respective issues as necessary.

\* This section corresponds to the following items of “II. Objective of Research”: Both gas/liquid phases are described together.

(3) (i) Conceptual Study and Development Planning of Detection Technologies and Systems for  $\alpha$  Nuclides in Gas Phase

(3) (ii) Conceptual Study and Development Planning of Detection Technologies and Systems for  $\alpha$  Nuclides in Liquid Phase

## VI. Implementation Details

### (3) Studying $\alpha$ Nuclide Monitoring System for Fuel Debris Retrieval

#### 1) $\alpha$ Nuclide Monitoring Overview

A fuel debris retrieval process will be carried out by monitoring various plant parameters to confirm they are within the normal range.

The monitoring of radioactive materials is part of this process and monitoring targets are specified depending on the purposes ( $\alpha$ ,  $\beta$ ,  $\gamma$ , and neutron fluxes, for example). For reasons shown below, it is required to consider the applicability of existing  $\alpha$  nuclide monitoring technologies (i.e. to confirm whether new items should be developed).

- Since nuclear fuel materials are processed and then retrieved in a fuel debris retrieval process, a significant amount of  $\alpha$  nuclides (whose impact of internal exposure is extremely large) including Pu is expected to be dispersed as well as FPs (fission products). Therefore, it is crucial to monitor  $\alpha$  nuclides.
- FP monitoring technologies have been well established in nuclear facilities (despite some issues including that their installation locations are high radiation areas).
- Although there are some cases where  $\alpha$  nuclide monitoring is applied in the reprocessing and fuel processing facilities, the situation revolving around fuel debris retrieval is substantially different from that in the existing facilities.

Debris retrieval is a **step-by-step** process, and **the system is reviewed in the following steps**. Similarly, in the  $\alpha$  nuclide monitoring, measurement ranges are reviewed in response to the amount retrieved **and** the know-hows obtained are reflected as necessary.

## VI. Implementation Details

### (3) Studying $\alpha$ Nuclide Monitoring System for Fuel Debris Retrieval

#### 2) Study Items

Item	Study Items
Clarifying Purposes for Monitoring $\alpha$ Nuclides	Sort out the measurement purposes since the monitoring location and measurement range vary depending on the purpose.
Provisional Setting of $\alpha$ Nuclide Monitoring Positions	Monitoring locations vary depending on the purposes and the estimated concentration is different at each monitoring location. Provisional monitoring locations are set to review the measurement range.
Studying Measurement Range	The required measurement range is reviewed for each provisional monitoring location.
Researching on and Clarifying Specifications of Existing $\alpha$ Nuclide Monitors	Existing $\alpha$ nuclide monitors are surveyed and their specifications are sorted out to review their compatibility.
Reviewing the Applicability of Existing $\alpha$ Nuclide Monitors and Identifying Issues	Based on the results of researching on and clarifying specifications of existing $\alpha$ nuclide monitors, the compatibility of existing technologies is reviewed in terms of the measurement range, etc. and issues are identified.
Reviewing Alternatives in Case of Incompatibility (Necessity of System Modification or Development)	When it is hard to solve issues related to the compatibility of existing $\alpha$ nuclide monitors, system modifications are reviewed, development elements are sorted out, and development plans are created as necessary.

## VI. Implementation Details

### (3) Studying $\alpha$ Nuclide Monitoring System for Fuel Debris Retrieval

#### 3) $\alpha$ Nuclide Monitoring Review Process Flow

The  $\alpha$  nuclide monitoring review proceeds based on the flow shown below. For the priority of review items, **the gas system takes precedence** because it has a greater impact when emitted to the environment and breathed in by personnel (i.e. internal exposure).

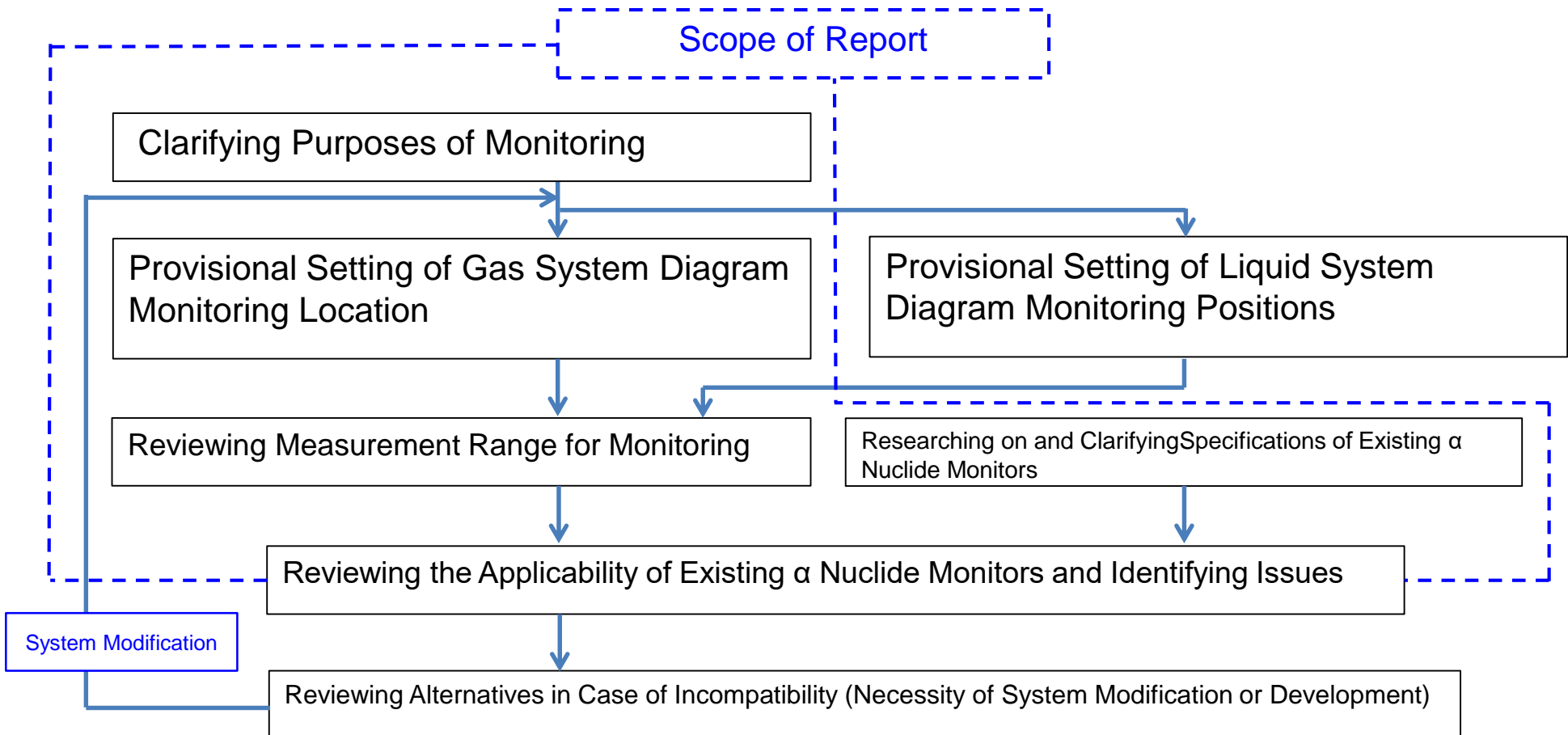

## VI. Implementation Details

(3) Studying  $\alpha$  Nuclide Monitoring System for Fuel Debris Retrieval

### 4) Purposes for Monitoring $\alpha$ Nuclides and Monitoring Positions

The targets of protection are divided into “Impact on the General Public (Outside of Perimeter)” and “Impact on Workers.” The monitoring purposes are classified into “Operation Monitoring (Monitoring of Concentration Changes inside PCV during Retrieval),” “Emission Monitoring (Emission Control),” and “Leak Detection.”

Item		Radiation Protection	
		I. Impact on the General Public (Outside of Perimeter)	II. Impact on Workers
Gas System	Under Normal Operation	<ul style="list-style-type: none"> <li>Emission control is guaranteed with continuous monitoring (<b>Emission Monitoring</b>).</li> </ul>	<ul style="list-style-type: none"> <li>There are leaks within the building under the normal operation conditions. Workers outside the building are included in Category I.</li> </ul>
	In Emergencies	<ul style="list-style-type: none"> <li>The amount of <math>\alpha</math> nuclide emission is monitored at the secondary boundary (<b>Emission Monitoring</b>).</li> <li>Monitoring the <math>\alpha</math> nuclide concentration inside the PCV (primary boundary) enables early detection of abnormalities (<b>Operation Monitoring</b>).</li> </ul>	<ul style="list-style-type: none"> <li>Abnormalities including leaks are detected early (to evacuate workers in the building) (<b>Leak Detection</b>).</li> <li>Monitoring the <math>\alpha</math> nuclide concentration inside the PCV (primary boundary) enables early detection of abnormalities (<b>Operation Monitoring</b>).</li> </ul>

Also, the measurement ranges were reviewed assuming the following measurement locations suitable for each purpose:

- Operation Monitoring: (i) A location where the atmosphere inside the PCV can be monitored
- Emission Monitoring: (ii) A location where the amount of emission from the exhaust end can be monitored
- Leak Detection: (iii) A location where leaks from the primary boundary can be detected



## VI. Implementation Details

### (3) Studying $\alpha$ Nuclide Monitoring System for Fuel Debris Retrieval

#### 5) Measurement Range Requirements

In reviewing the measurement range, it is necessary to comprehensively determine the upper limit ( $\alpha$  radioactivity concentration expected in the operation range) and the lower limit (requirements of the laws and regulations, monitoring criteria, etc.) of the measurement range required for monitoring. To this end, concentrations to be measured were reviewed by dividing them into the following categories.

- **Estimated Radioactivity Concentration in the Design**

Set based on the evaluations of the atmosphere inside the PCV and radioactivity concentration at exhaust outlets under the assumption of full-scale debris retrieval.

- **Limits of Concentration in the Air as Stipulated in Laws and Regulations**

Set based on the upper concentration limits stipulated in laws and regulations concerning the air outside the supervised area and the respiration of radiation workers.

- **Monitoring Criteria**

Set based on the measurement guidelines for released radioactive materials, the measurement guidelines for radiation under emergency operating conditions, and the guidelines for radiation monitoring (JEAG4606-2017).

- **Current Background/Action Levels**

Set based on the target lower limit of detection and action level set in the current R/B dust sampling process.

Measurement range requirements were specified for each monitoring location [based on the above review results](#).

## VI. Implementation Details

(3) Studying  $\alpha$  Nuclide Monitoring System for Fuel Debris Retrieval

### 6) Summary

- In FY 2017, mainly in the gas system, the purposes of  $\alpha$  nuclide monitoring, the measurement range, have been reviewed, and existing  $\alpha$  nuclide monitors identified, their specifications surveyed, and their compatibility reviewed.
- In FY 2018, the liquid system will mainly be reviewed, and, if issues are found in applying existing  $\alpha$  nuclide monitoring technologies, alternatives reviewed.

Item	FY 2017	FY 2018
Clarifying Purposes	Gas System	Liquid System
Setting Various Conditions for Review (Required Measurement Range)	Gas System	Liquid System
Researching on and Clarifying Specifications of Existing $\alpha$ Nuclide Monitors	Gas System	Liquid System
Reviewing the Applicability of $\alpha$ Nuclide Monitors in the Gas System	Gas System	
Reviewing the Applicability of $\alpha$ Nuclide Monitors in the Liquid System		Liquid System
Summary (Reviewing Alternatives and the Need for Development)		

# VI. (4) Study on Optimization of Ensuring Safety of Methods and Systems

## (i) Study on Optimization of Ensuring Safety of Methods

### 1) Review of Method Design Conditions

The design conditions required to review fuel debris retrieval methods were sorted out and optimized.

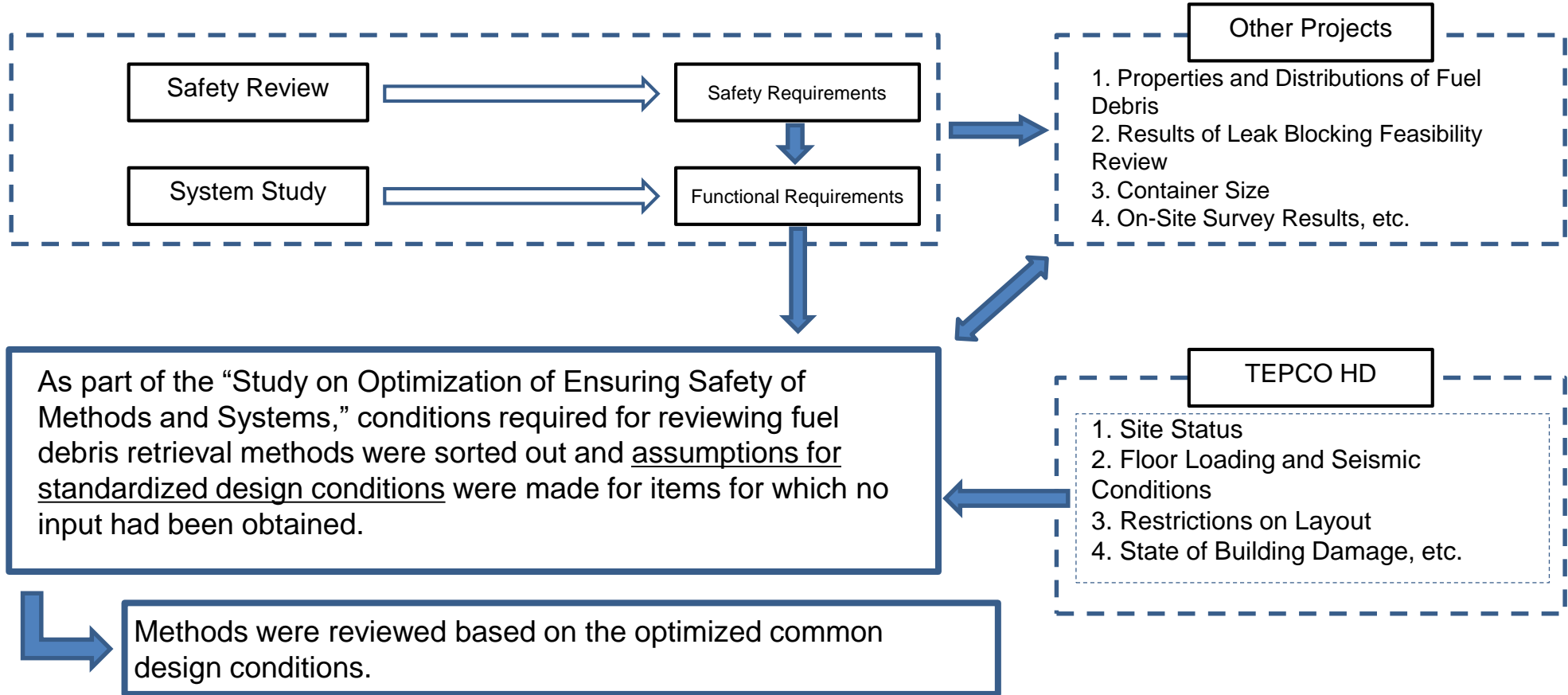

: Scope to Be Reviewed in Method Review : Input and Output

# VI. (4) Study on Optimization of Ensuring Safety of Methods and Systems

## (i) Study on Optimization of Ensuring Safety of Methods

### 2) Identifying and Taking Measures against Issues Common to All Methods

#### (i) Floor Loading Limit

An action policy to deal with the floor loading limit on the first floor of the R/B, an issue common to all side access methods was developed .

PLAN-A			PLAN-B			PLAN-C		
<p>Layout Example for Unit 2</p>			<p>Layout Example for Unit 1</p>			<p>Layout Example for Unit 2</p>		
Cell Weight in R/B	Floor Loading	Floor Loading Capacity	Cell Weight in R/B	Floor Loading	Floor Loading Capacity	Cell Weight in R/B	Floor Loading	Floor Loading Capacity
Weight Reduction under Consideration	≤ 4.9 ton/m <sup>2</sup>	4.9 ton/m <sup>2</sup>	Weight Reduction under Consideration	0 ton/m <sup>2</sup>	4.88 ton/m <sup>2</sup>	Weight Reduction under Consideration	≤ 7 ton/m <sup>2</sup>	4.9 ton/m <sup>2</sup>
<ul style="list-style-type: none"> <li>This plan is based on the idea to lay out all cells straight and construct a relatively large opening in the outer wall of the R/B.</li> <li>The cells are carried in and installed via conveyor rails from outside the R/B.</li> <li>The reinforcement of the opening needs to be considered to maintain the integrity of the R/B (since the opening imposes a relatively large load on the R/B).</li> <li>A reduction in floor loading is under consideration by using a suspension-bridge type structure that can release the load to the outside.</li> <li>This method supports the cells' load at both ends by the BSW and support point on the outside of the R/B.</li> </ul>			<ul style="list-style-type: none"> <li>A method is under consideration to connect an extension building built outside the R/B and the PCV with an access tunnel.</li> <li>Our plan is to support the weight of the access tunnel at both ends by the BSW and the R/B walls so that no load is imposed on the first floor of the R/B.</li> </ul>			<ul style="list-style-type: none"> <li>Cells and a transport carriage etc. are positioned on the first floor of the R/B.</li> <li>Equipment requiring maintenance and fuel debris are transferred by the carriage to the external extension building.</li> <li>A reduction in floor loading is under consideration by transferring the load of the equipment cell and carriage to the large beams, the BSW, and the R/B walls. Our plan is to reduce the floor loading by distributing the load with steel floor plates.</li> </ul>		

# VI. (4) Study on Optimization of Ensuring Safety of Methods and Systems

## (i) Study on Optimization of Ensuring Safety of Methods

### 3) Reviewing Side Access Methods

#### (i) PLAN-A: Flow Chart

Concepts: To minimize tasks performed inside PCV



- Reduce Workers' Exposure
- Improve Maintainability of Remote Equipment

Unit Canister	: $\phi 200 \times H200$	(Fuel Debris: Equivalent of about 15 kg, estimated filling rate at 0.3)
Storage Canister	: A Group of 4 Unit Cans	(Fuel Debris: Equivalent of about 60 kg)
Cask	: A Group of 5 Canisters	(Fuel Debris: Equivalent of about 300 kg)

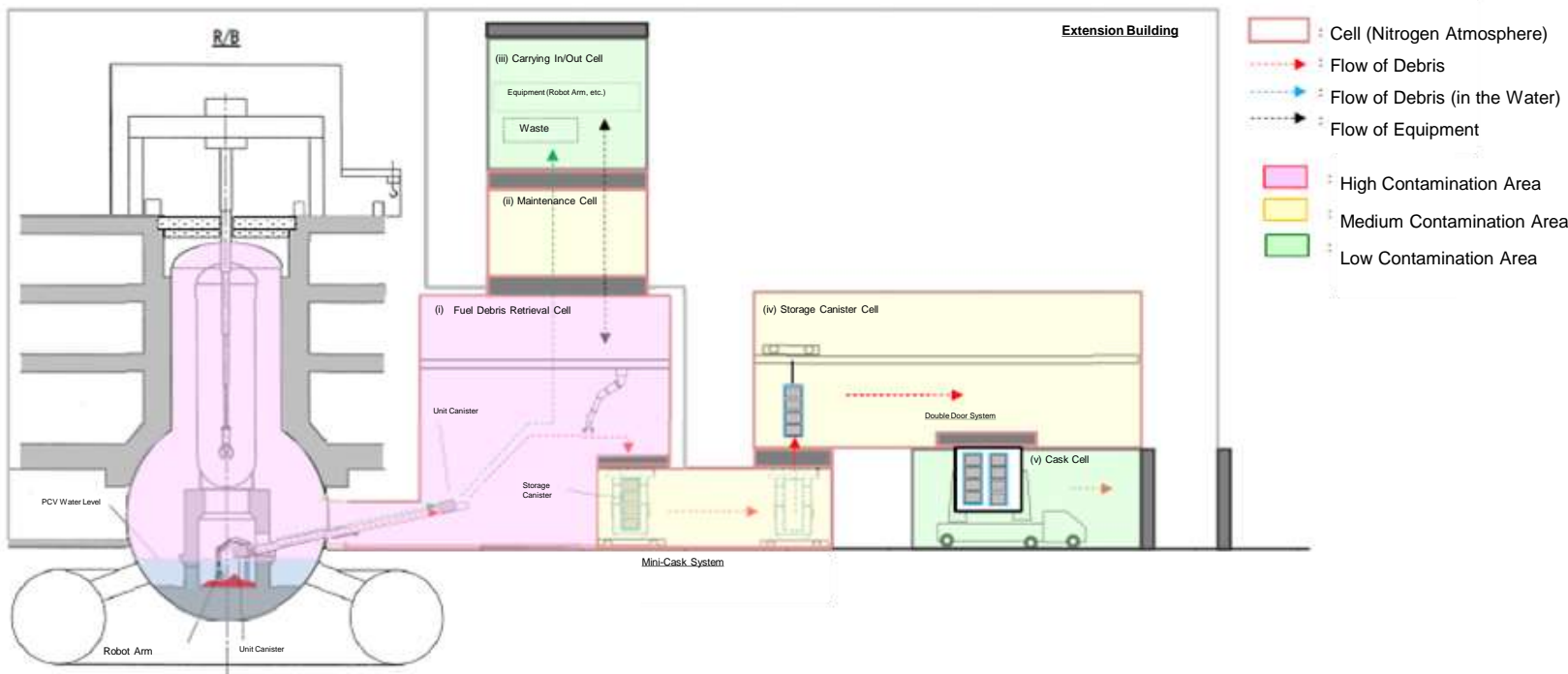
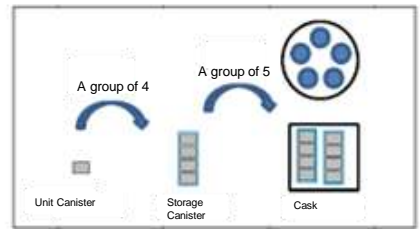

# VI. (4) Study on Optimization of Ensuring Safety of Methods and Systems

## (i) Study on Optimization of Ensuring Safety of Methods

### 3) Reviewing Side Access Methods

#### (i) PLAN-A: Step Diagram

(Fuel Debris Retrieval Tasks/ Fuel Debris Retrieval Tasks Inside Pedestal (Robot Arm, Access Rail))

1. Carry the robot arm into the cell.	2. Insert the robot arm into the access rail.	3. Mount the robot arm on the access rail.	4. Tilt the access rail toward the opening for CRD replacement.
5. Extend the access rail.	6. Move forward and expand the robot arm.	7. Access the fuel debris with the robot arm.	8. Cut the fuel debris with a tool attached to the front edge of the arm.
9. Collect fuel debris fragments in a unit canister placed in the transport carriage on the access rail.	10. Transfer the unit canister to the cell using the transport carriage on the rail.	11. Access the unit canister with a manipulator in the cell.	12. Store fuel debris contained in the unit canister in a storage canister with the manipulator in the cell.

# VI. (4) Study on Optimization of Ensuring Safety of Methods and Systems

## (i) Study on Optimization of Ensuring Safety of Methods

### 3) Reviewing Side Access Methods

#### (ii) PLAN-B: Flow and Area Classification Diagrams

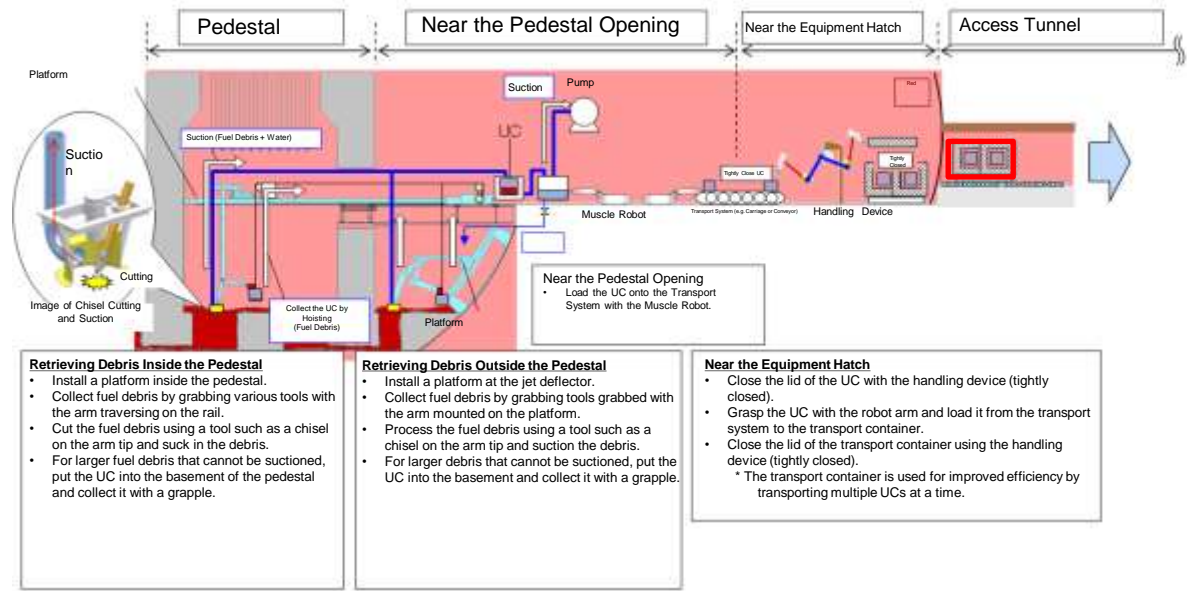

### Concepts of PLAN-B

- A method applicable to all units by using an access tunnel.
- High degree of freedom in layout through access tunnel routing.
- Utilizes the existing equipment hatch. (Minimizes load (including floor loading) on damaged R/B) (Applicable even for an opening larger than X-6 penetration.)
- A retrieval device approaches and retrieves fuel debris.



### Feasibility Verification by Fundamental Technology Development

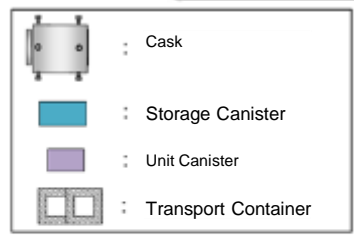

Red box: Points where Airtightness is Ensured

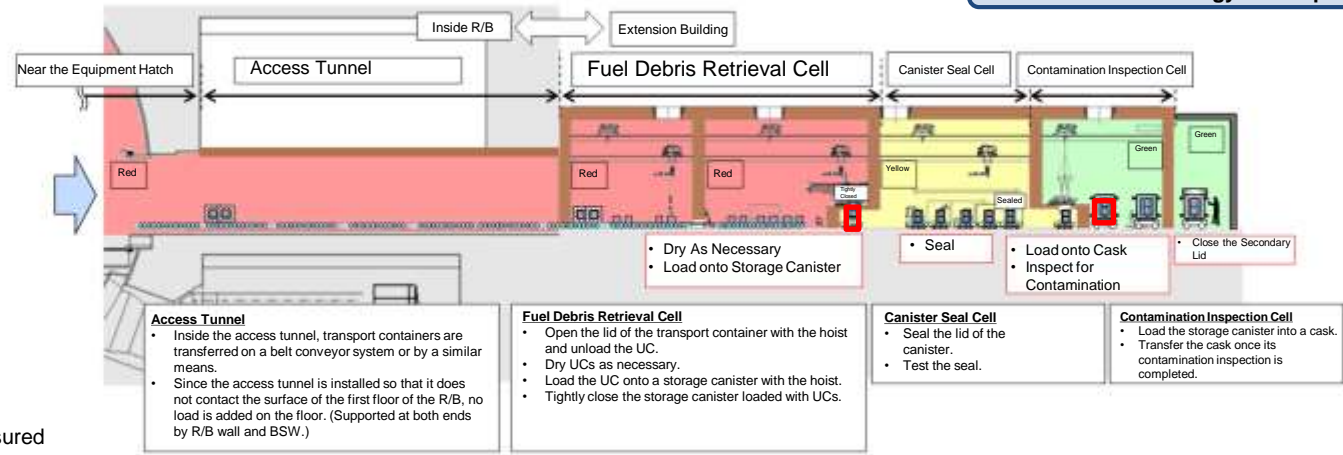

# VI. (4) Study on Optimization of Ensuring Safety of Methods and Systems

## (i) Study on Optimization of Ensuring Safety of Methods

### 3) Reviewing Side Access Methods

#### (ii) PLAN-B: Step Diagram (Preparation of PCV Interior/Removal of Fuel Debris Inside/Outside Pedestal/Handing Over to Storage Canister)

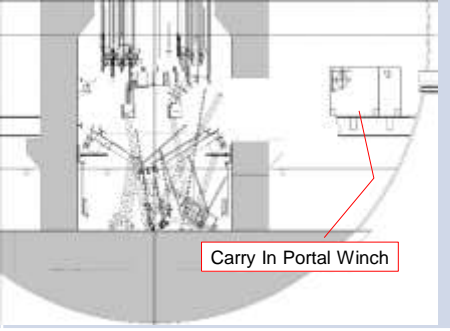
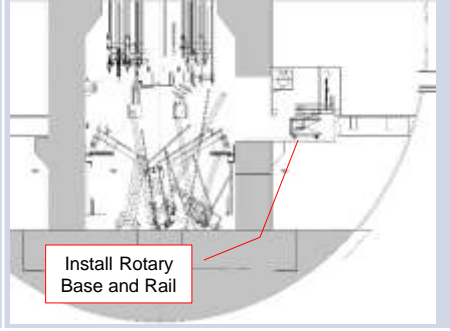
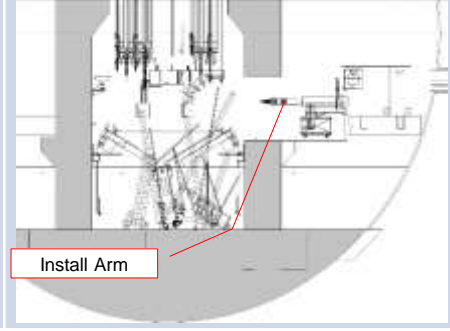
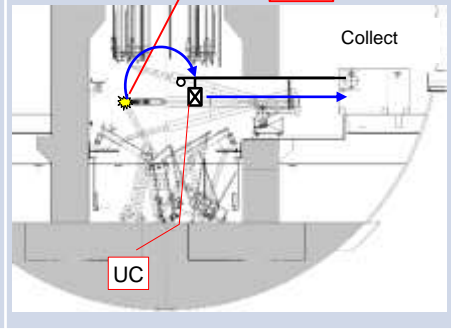
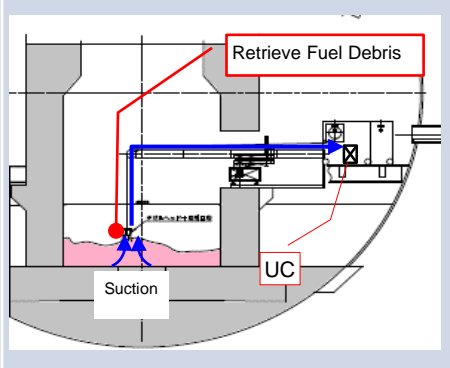
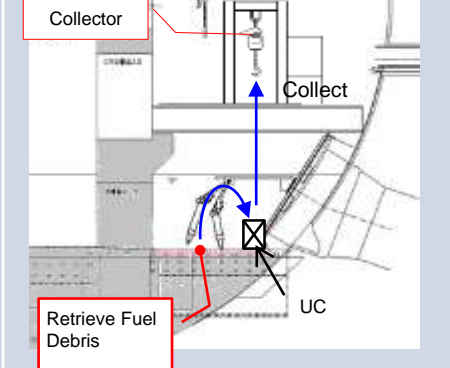
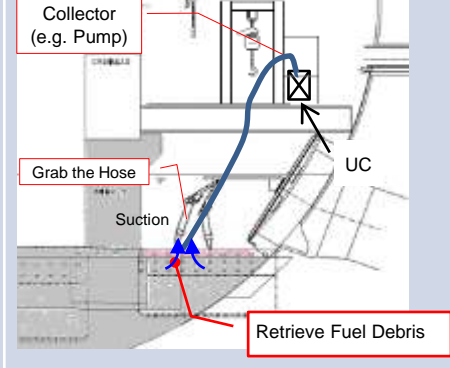
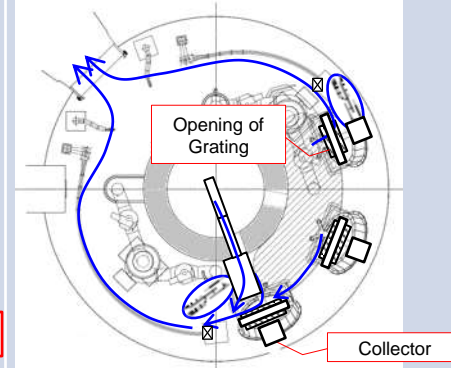
Task Steps	Carry In Retrieval Equipment	Install Retrieval Equipment (i)	Install Retrieval Equipment (ii)	Retrieval of Fuel Debris (Obstacles) Inside Pedestal (Grabbing)
Step Diagram	 <p>Carry In Portal Winch</p>	 <p>Install Rotary Base and Rail</p>	 <p>Install Arm</p>	 <p>Remove</p> <p>Collect</p> <p>UC</p>
Task Steps	Example of Retrieval for Fuel Debris Inside Pedestal (Cutting and Suction)	Retrieval of Fuel Debris Outside Pedestal (Grabbing)	Retrieval of Fuel Debris Outside Pedestal (Suction)	Fuel Debris Transfer (i) (Using Transport System)
Step Diagram	 <p>Retrieve Fuel Debris</p> <p>Suction</p> <p>UC</p>	 <p>Collector</p> <p>Collect</p> <p>UC</p> <p>Retrieve Fuel Debris</p>	 <p>Collector (e.g. Pump)</p> <p>Grab the Hose</p> <p>Suction</p> <p>UC</p> <p>Retrieve Fuel Debris</p>	 <p>Opening of Grating</p> <p>Collector</p>



# VI. (4) Study on Optimization of Ensuring Safety of Methods and Systems

## (i) Study on Optimization of Ensuring Safety of Methods

### 3) Reviewing Side Access Methods

#### (ii) PLAN-B: Step Diagram (Preparation of PCV Interior/Removal of Fuel Debris Inside/Outside Pedestal/Handing Over to Storage Canister)

An element test is being planned to verify obstacle removal feasibility.

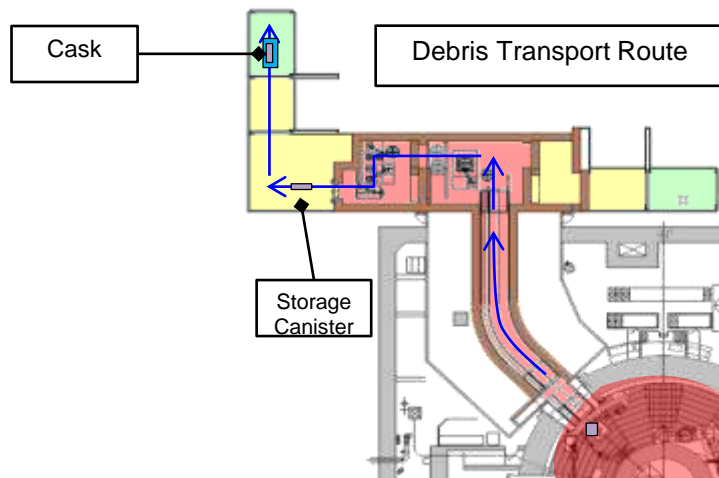
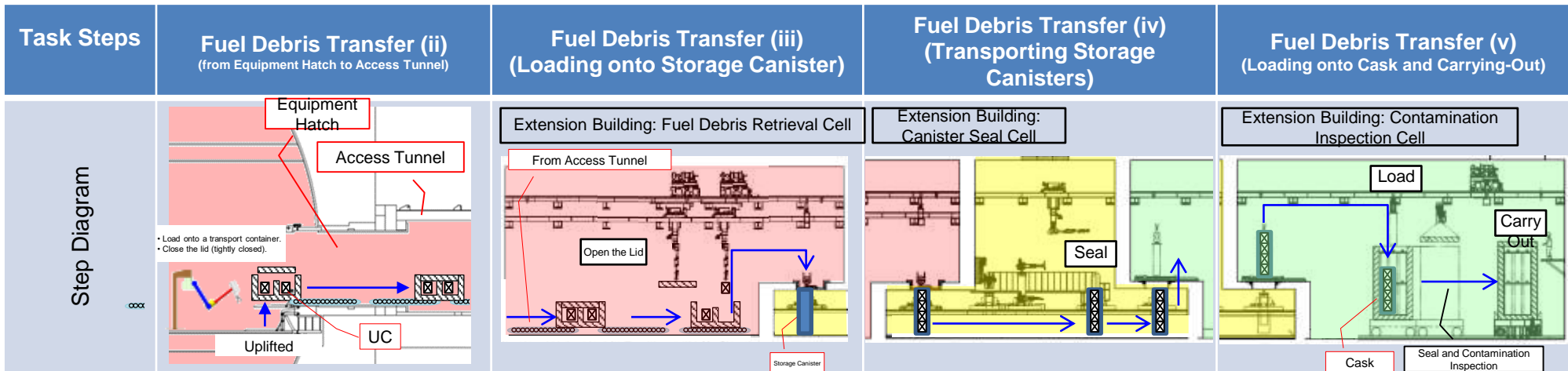

\* As a mechanism for transporting debris between boundaries, double doors and air locks are being considered.

# VI. (4) Study on Optimization of Ensuring Safety of Methods and Systems

## (i) Study on Optimization of Ensuring Safety of Methods

### 3) Reviewing Side Access Methods

#### (iii) PLAN-C: Appearance

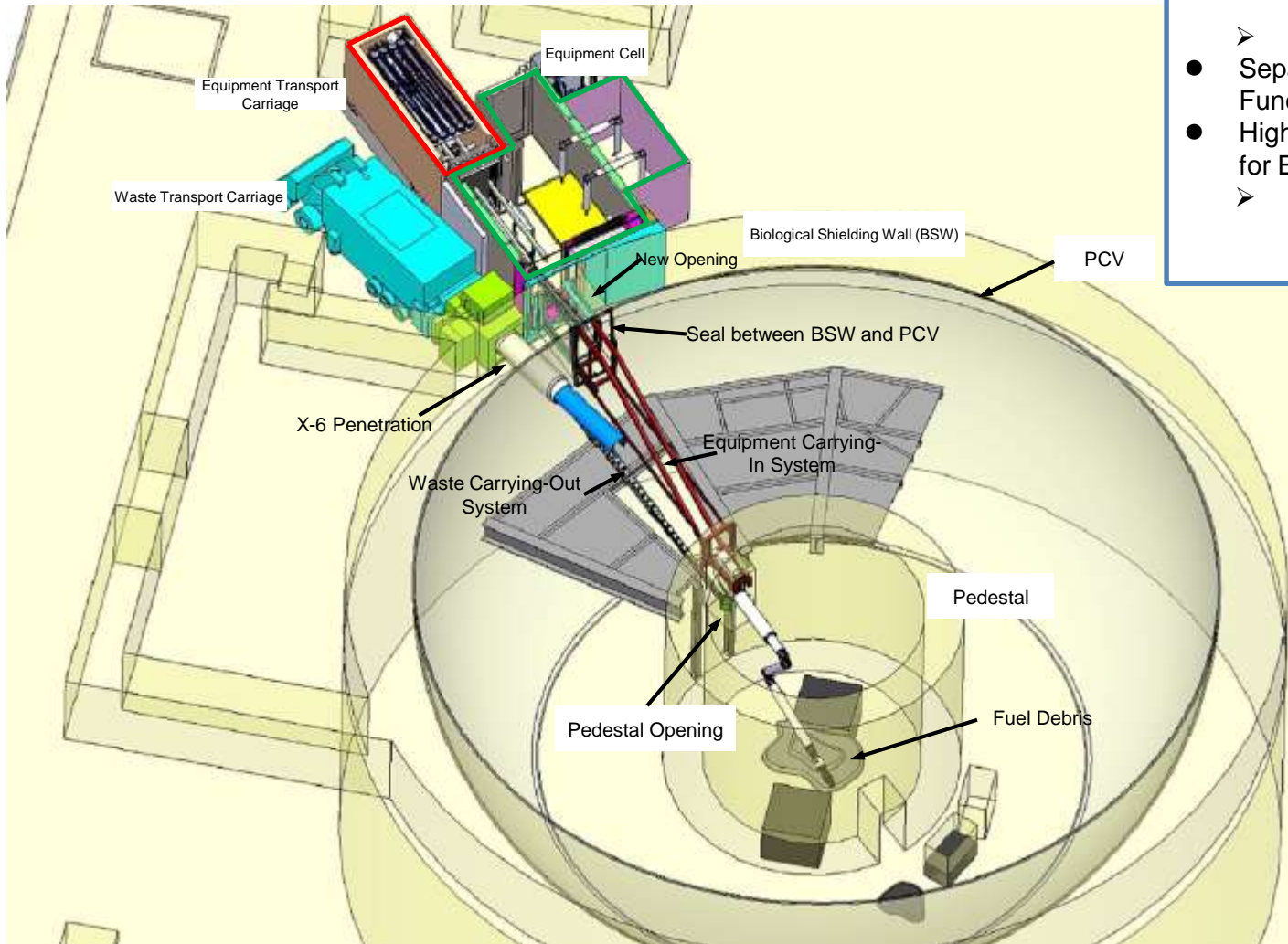

#### Concepts of PLAN-C

- Minimize the area that requires obstacle removal.
  - No major obstacles (e.g. larger size piping) on its access route inside PCV
  - No new openings required on R/B
- Separate Cells and Traffic Lines for Each Function
- High Degree of Freedom in Determining Layout for Extension Buildings
  - Waste is transported using a waste transport carriage.

# VI. (4) Study on Optimization of Ensuring Safety of Methods and Systems

## (i) Study on Optimization of Ensuring Safety of Methods

### 3) Reviewing Side Access Methods

#### (iii) PLAN-C: Flow and Area Classification Diagrams

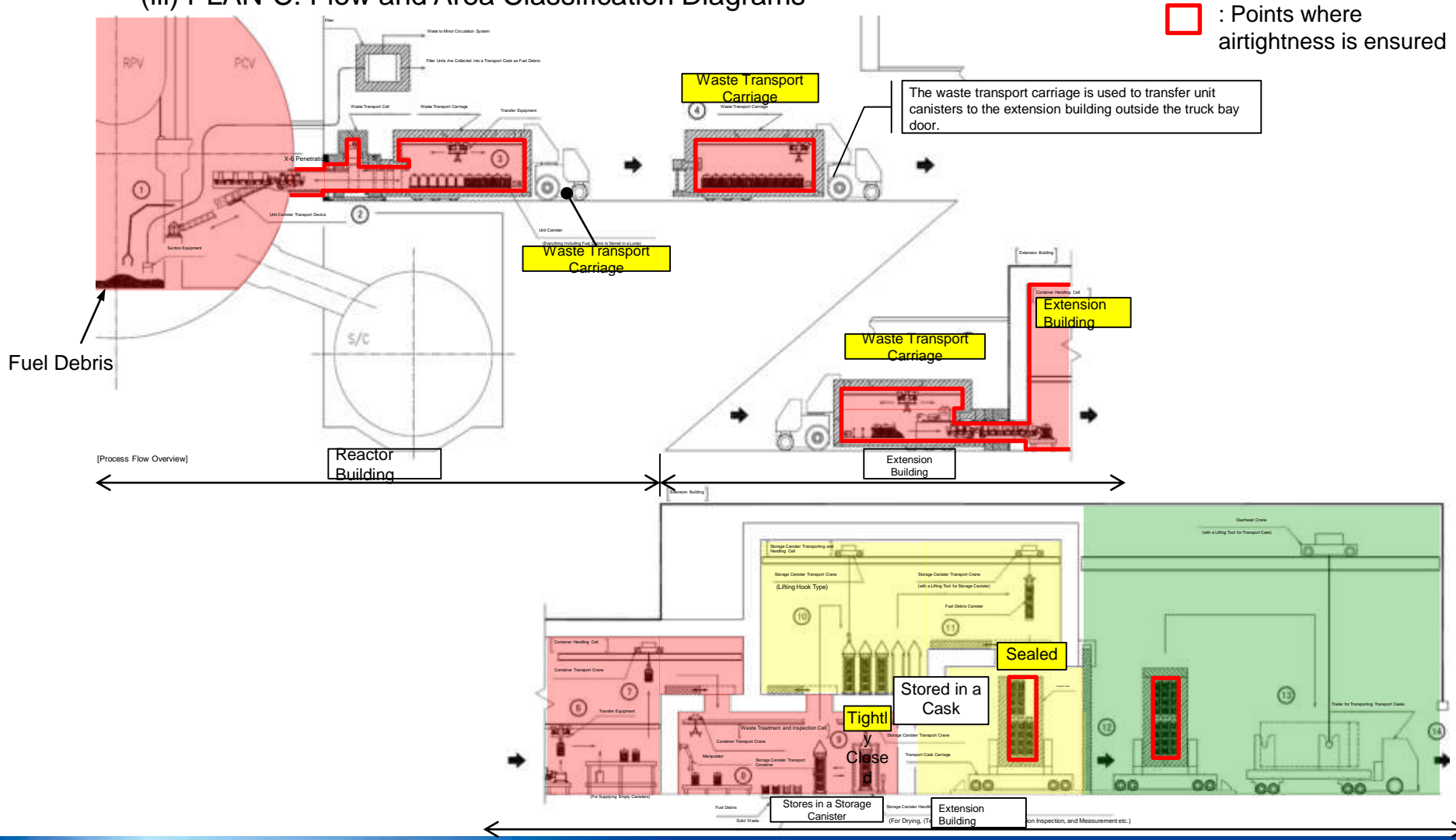

# VI. (4) Study on Optimization of Ensuring Safety of Methods and Systems

## (i) Study on Optimization of Ensuring Safety of Methods

### 3) Reviewing Side Access Methods

#### (iii) PLAN-C: Step Diagram (Fuel Debris Retrieval/ Removing Structures and Fuel Debris in and outside Pedestal )

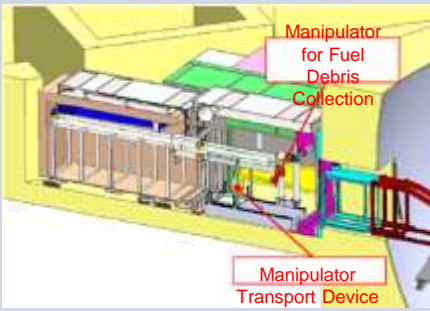
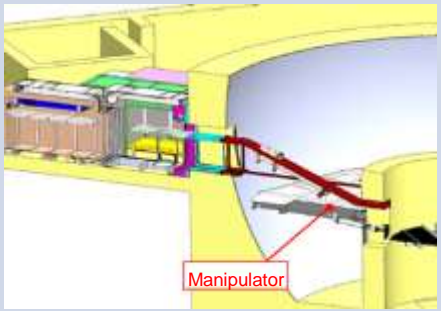
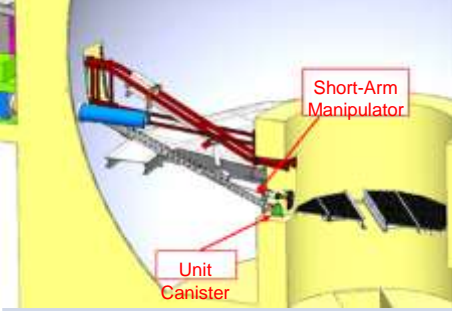
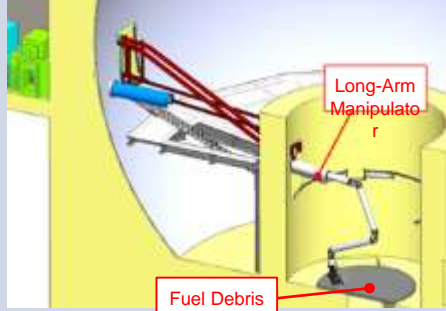
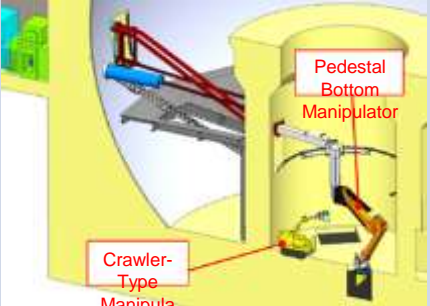
Task Steps	Carrying Manipulator for Fuel Debris Collection into Equipment Cell 1	Carrying Manipulator for Fuel Debris Collection into Equipment Cell 2	Collecting Structures and Fuel Debris Inside RPV Pedestal (i)-1	Collecting Structures and Fuel Debris Inside RPV Pedestal (i)-2
Step Diagram	 <p>Labels: Manipulator for Fuel Debris Collection, Manipulator Transport Device</p>	 <p>Label: Manipulator</p>	 <p>Labels: Short-Arm Manipulator, Unit Canister</p>	 <p>Labels: Long-Arm Manipulator, Fuel Debris</p>
Task Steps	Collecting Structures and Fuel Debris Inside RPV Pedestal (ii)			
Step Diagram	 <p>Labels: Pedestal Bottom Manipulator, Crawler-Type Manipulator</p>			

# VI. (4) Study on Optimization of Ensuring Safety of Methods and Systems

## (ii) Study on Optimization of Ensuring Safety of Systems

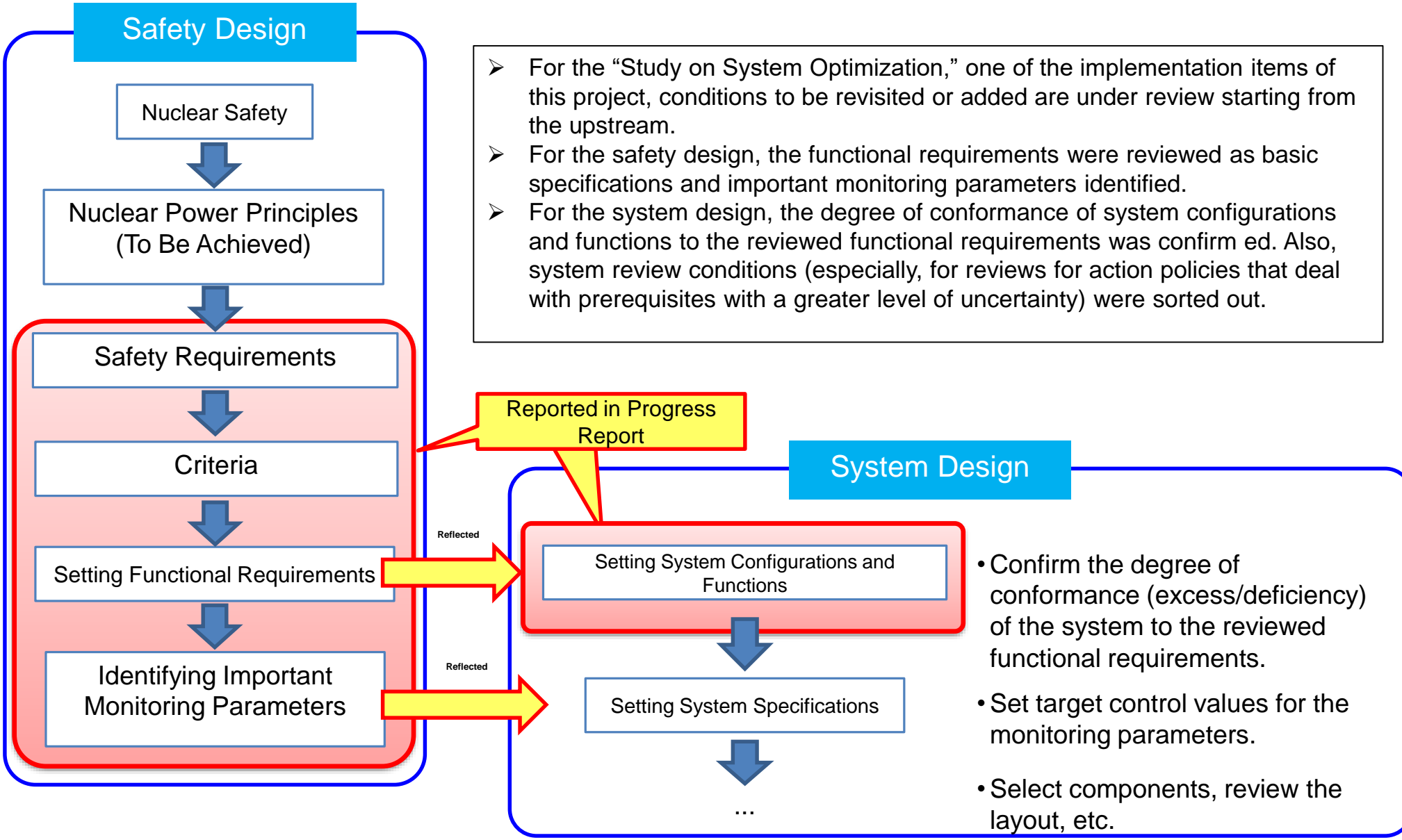

# VI. (4) Study on Optimization of Ensuring Safety of Methods and Systems

## (ii) Study on Optimization of Ensuring Safety of Systems

### (a) Brushing Up System Concepts

The system for optimization has been reviewed based on the review conducted last year. The figure below shows the flow of the review.

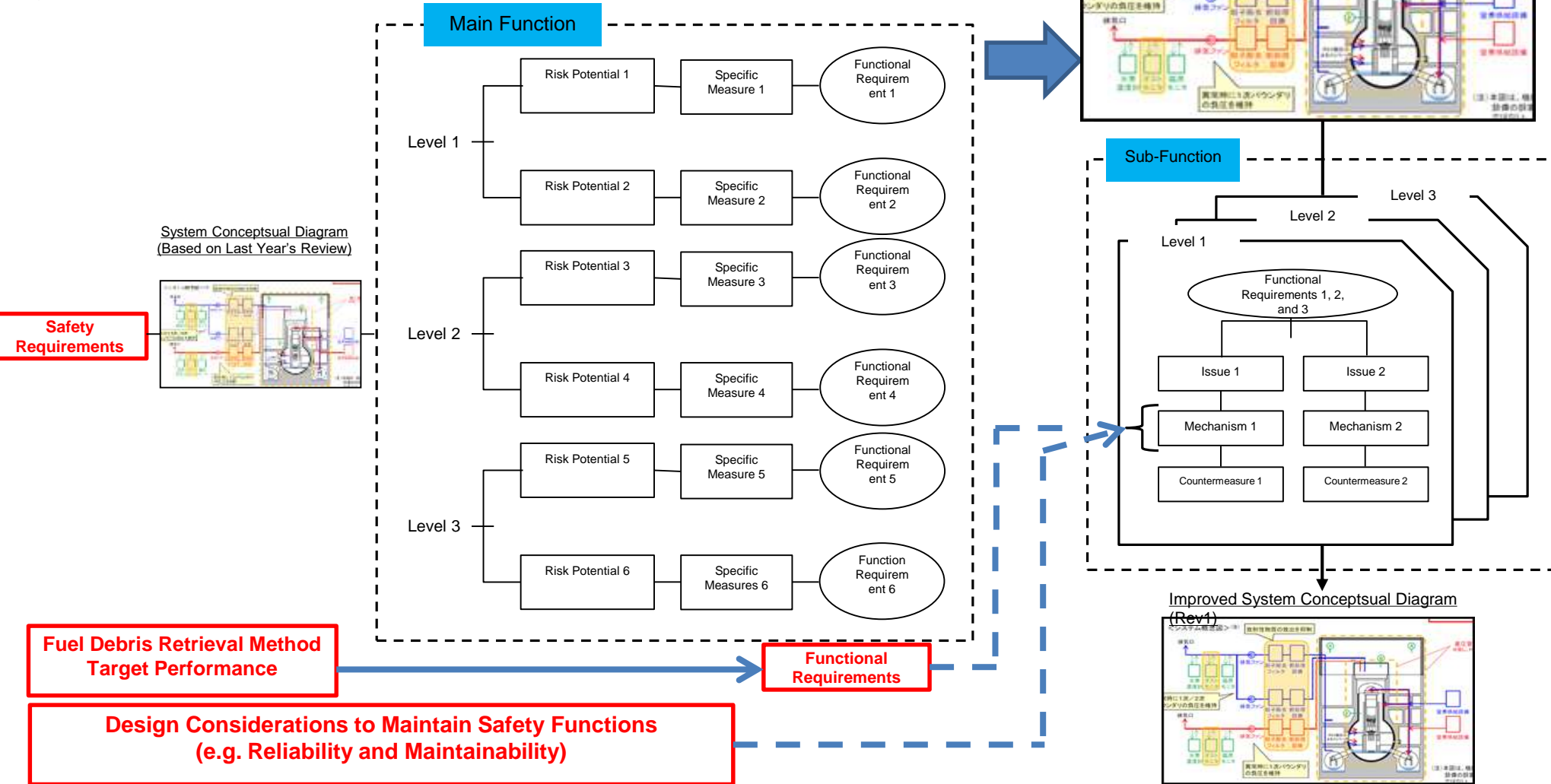

Figure - Breaking Down Safety Requirements into Practical Design

## VI. (4) Study on Optimization of Ensuring Safety of Methods and Systems

### (ii) Study on Optimization of Ensuring Safety of Systems

#### (a) Brushing Up System Concepts

#### 1) Revisiting the Safety Requirements (1/2)

This year, the safety requirements were revisited in terms of the following aspects:

- To clearly identify items to be achieved (e.g., safety standards) in defining the safety requirements for a fuel debris retrieval facility in a specified nuclear facility for nuclear safety purposes.
- To add requirements for protecting workers from radioactive risks, as workers play an integral role in fuel debris retrieval tasks in a specified nuclear facility, and radiation protection measures taken for the environment in which workers perform system maintenance and inspection tasks have an impact on the system's feasibility.
- To prevent combustion and explosions caused by flammable gas and metallic powder as safety requirements, taking into account the characteristics of a specified nuclear facility.

(The safety requirements set this year are shown in the following pages.)

# VI. (4) Study on Optimization of Ensuring Safety of Methods and Systems

## (ii) Study on Optimization of Ensuring Safety of Systems

### (a) Brushing Up System Concepts

#### 1) Revisiting the Safety Requirements (2/2)

Nuclear Safety		Safety Principles (To Be Achieved)		Basic Safety Requirements	Safety Requirements (Example)
Protect People and the Environment from Radioactive Risks	Protect the Public and the Environment from Radioactive Risks	Prevent Excessive Emission of Radioactive Materials	Confine Radioactive Materials	Confine radioactive materials by setting a boundary	Prevent leakage that exceeds the allowable level specified in the safety standards for radioactive materials in gas
					Prevent leakage that exceeds the allowable level specified in the safety standards for radioactive materials in liquid system
			Confine radioactive materials retrieved from within the reactor with transport containers	Prevent leakage of radioactive materials from transport containers	
		Prevent Abnormal Generation of Additional Radioactive Materials	Prevent additional nuclear fission reactions	Prevention of abnormal generation of radioactive materials caused by criticality	
			Prevent abnormal overheating	Prevention of the emission of radioactive materials due to abnormal temperature rise in fuel debris	
			Prevent abnormal diffusion of radioactive materials caused by cutting operation	Prevention of abnormal diffusion of radioactive materials caused by cutting fuel debris and structures	
		Prevent Excessive Radioactive Exposure	Protect against external exposure	Shields for preventing excessive direct radiation exposure	
	Protect Workers from Radioactive Risks	Prevent Workers from Excessive External and Internal Exposures - Exposure Associated with Installing New Equipment Required for Debris Retrieval Tasks - Exposure Associated with Debris Retrieval Related Tasks - Exposure of Site Workers Due to Tasks Other than Debris Retrieval Related Tasks		Design for dose reduction for workers	Shields, appropriate classifications for the level of contamination and dose, and system designs for remote maintenance and traffic line setting, etc. to reduce exposure
				Operation control for dose reduction for workers	Operation methods, maintenance plans, and task management for dose reduction



## VI. (4) Study on Optimization of Ensuring Safety of Methods and Systems

(ii) Study on Optimization of Ensuring Safety of Systems

(a) Brushing Up System Concepts

### 2) Revisiting the Functional Requirements (1/3)

- Systematically organized functional requirements to respond potential risks for each safety requirements.
- Functional requirements were specified for each level of defense in depth. Requirements were clearly stated for cases that assume the loss of a function at the previous stage, as they are an important prerequisite for the system design.
- As design conditions were not yet finalized for explosions caused by flammable gas and metallic power, multiple functional requirements were proposed.

(The functional requirements set this year are shown in the following pages.)

# VI. (4) Study on Optimization of Ensuring Safety of Methods and Systems

## (ii) Study on Optimization of Ensuring Safety of Systems

### (a) Brushing Up System Concepts

### 2) Revisiting the Functional Requirements (2/3)

Safety Requirements	Level	Functional Requirements (Tentative)
Prevent leakage that exceeds the allowable level specified in the safety standards for radioactive materials in gas	Levels 1 and 2	Reduce the radioactive material concentration in the gas phase within the boundary to a value equal to or less than the control standard value
		Prevent radioactive material leakage in the gas phase using a static boundary except in areas that depend on a dynamic boundary
		Prevent radioactive material leakage in the gas phase that exceeds the allowable level specified in the safety standards using a dynamic boundary
		Prevent the emission of radioactive materials in the gas phase to the environment that exceeds the allowable level specified in the safety standards in the exhaust to maintain a dynamic boundary
	Level 3	Capable of isolating the boundary (along isolatable emission routes) when needed (including in the case of criticality accidents and the loss of the debris cooldown function)
		Prevent radioactive material leakage in the gas phase using a static boundary except in areas that depend on a dynamic boundary under emergency operating conditions
		Prevent the emission of radioactive materials in the gas phase to the environment that exceeds the allowable level specified in the safety standards in the exhaust to maintain a dynamic boundary under emergency operating conditions
Prevent leakage that exceeds the allowable level specified in the safety standards for radioactive materials in liquid system	Levels 1 and 2	Prevent radioactive material leakage in the liquid phase using a static boundary in combination with the function to reduce the concentrations of radioactive materials in the liquid phase within the boundary to maintain the radioactivity concentration in the liquid phase in the torus room to a value equal to or less than the control standard value
		Reduce the radioactive material concentration in the liquid phase within the boundary to a value equal to or less than the control standard value
		Prevent radioactive material leakage in the liquid phase from the boundary through the opening in the gas phase to the torus room using a dynamic boundary
Prevent leakage that exceeds the allowable level specified in the safety standards for radioactive materials in liquid system	Levels 1 and 2	Prevent radioactive material leakage in the liquid phase from the torus room to the environment using the dynamic boundary
	Level 3	Prevent radioactive material leakage in the liquid phase from the torus room to the environment using the dynamic boundary
Prevent abnormal generation of radioactive materials caused by nuclear fission reactions	Levels 1 and 2	Maintain sub-criticality
	Level 3	Terminal the state of re-criticality of debris promptly when an accident occurs

# VI. (4) Study on Optimization of Ensuring Safety of Methods and Systems

## (ii) Study on Optimization of Ensuring Safety of Systems

### (a) Brushing Up System Concepts

#### 2) Revisiting the Functional Requirements (3/3)

Safety Requirements	Level	Functional Requirements (Tentative)
Prevention of the emission of radioactive materials due to abnormal temperature rise in fuel debris	Level 1	Cool down the debris so that the monitored value of temperature in the boundary does not rise abnormally
	Level 2	Cool down the debris so that, by the temperature rise in the debris, the concentrations of radioactive materials in the gas phase in the boundary becomes equal to or less than the control value set for a transition period
	Level 3	Cool down the debris so that, by the temperature rise in the debris, the concentrations of radioactive materials in the gas phase in the boundary becomes equal to or less than the control value set for emergency operating conditions
Prevention of abnormal diffusion of radioactive materials caused by cutting fuel debris and structures	Levels 1and2	Cut the debris and structures in a manner that makes the concentrations of radioactive materials within the boundary equal to or less than the control standard value with a help of the functions to reduce the concentration of radioactive materials in the gas and liquid phases within the boundary
Shields, appropriate classifications for the level of contamination and dose, and system designs for remote maintenance and traffic line setting, etc. to reduce exposure	Levels 1and2	Set appropriate classifications for the level of dose and contamination and design the system accordingly
	Level 3	Set appropriate classifications for the level of dose and contamination under emergency operating conditions and design the system accordingly
Operation methods, maintenance plans, and task management for dose reduction	Levels 1and2	Develop operation methods and maintenance plans so that the exposure level is equal to or below the safety standards, and manage tasks accordingly under normal operating conditions
	Level 3	Establish measures against accidents so that the exposure level is equal to or below the safety standards, and manage tasks accordingly
Maintain conditions under which fire is not caused by reactions between metallic powder and oxygen	Level 1	Reduce the oxygen concentration to a level equal to or below the control standard value
	Level 2	Capable of suppressing the generation of metallic powder in the event the oxygen concentration has exceeded the control standard value
	Level 3	Capable of reducing the concentration of metallic powder within the boundary in the event of a rapid rise in the oxygen concentration
Maintain flammable gas equal to or below its flammability limit to prevent fire and explosions	Levels 1and2	Reduce the oxygen concentration to a level equal to or below the control standard value
	Level 3	Maintain the hydrogen concentration equal to or below the control standard value in the event the oxygen concentration has exceeded the control standard value
Monitor the plant to understand its state	Levels 1–3	Have monitoring functions in place to understand the plant state
	Levels 1–3	Have monitoring functions in place to control radiation emission to the environment

## (ii) Study on Optimization of Ensuring Safety of Systems

### (a) Brushing Up System Concepts

### 3) Clearly Identifying Requirements Using Objective Trees

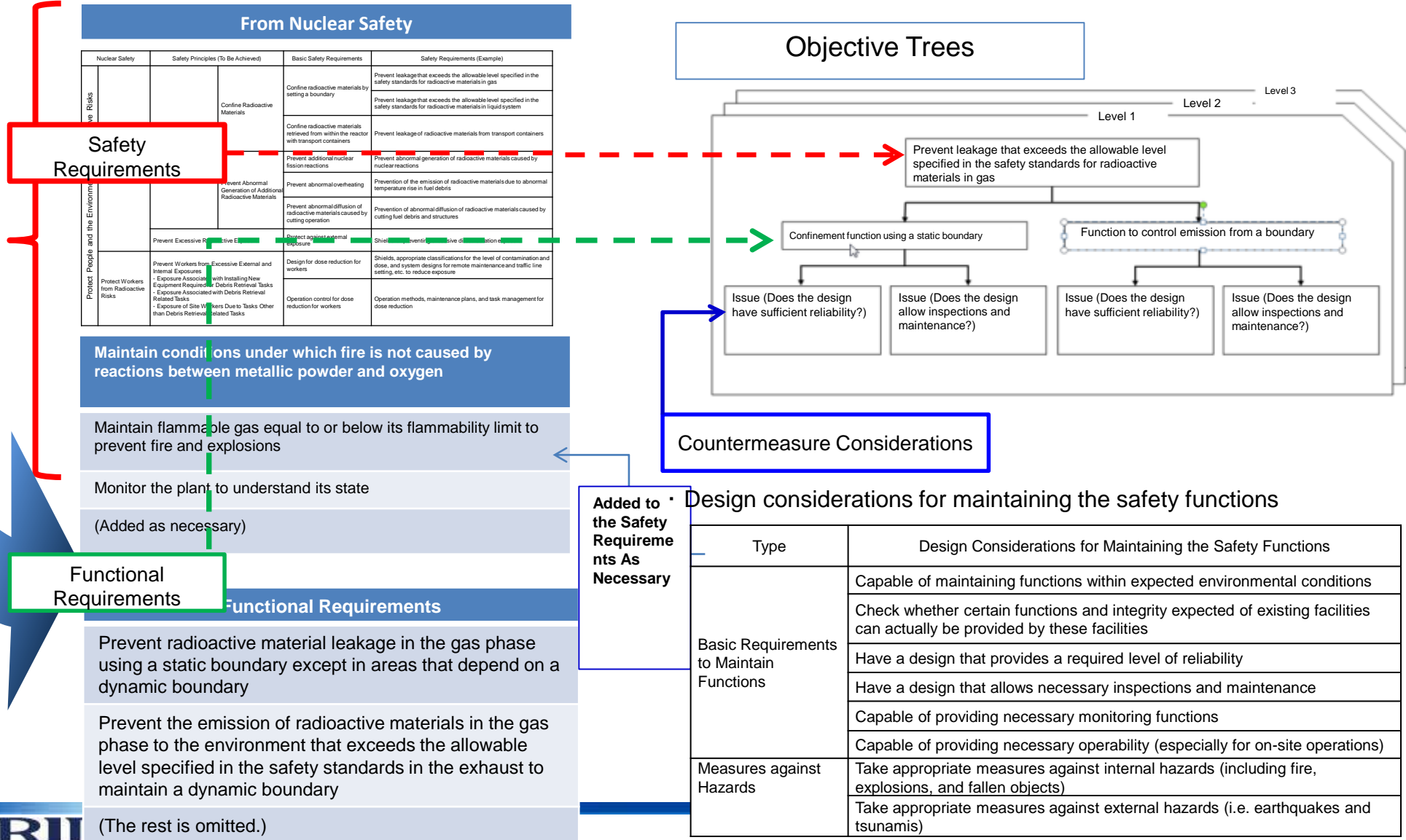

## VI. (4) Study on Optimization of Ensuring Safety of Methods and Systems

### (ii) Study on Optimization of Ensuring Safety of Systems

#### (b) Reviewing Target Control Values

Monitoring parameters and target control values are being reviewed in response to the functional requirement review.

• Important parameters were identified in terms of the following three aspects based on the functional requirements provided by the safety requirements.

(i) Parameters for which the judgement criteria are defined in functional requirements

(ii) Parameters for which the judgement criteria are not clearly defined in functional requirements, but required for quantitatively confirming that a functional requirement is met

(iii) Parameters which complements (i) and (ii) above

• Various settings and conditions values are being reviewed (including target control values, safety analysis condition values, and action levels) for the identified important parameters.

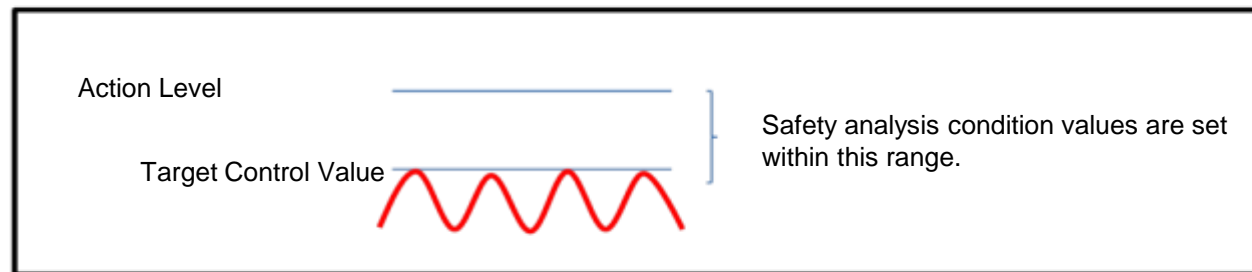

Figure - Relationship among Settings and Levels of Controlled State

# VI. (4) Study on Optimization of Ensuring Safety of Methods and Systems

## (ii) Study on Optimization of Ensuring Safety of Systems

### (c) Results of Exposure Assessment

(i) Exposure Assessment under Normal Operating Conditions	● Exposure assessment techniques at the site boundary under normal and emergency operating conditions had been put in place by FY 2016.
(ii) Exposure Assessment under Emergency Operating Conditions	● Evaluations to confirm feasibility, based on the exposure assessment for the site boundary <b>under normal and emergency operating conditions, were conducted in FY 2016.</b> ● Re-evaluations in light of changes that arouse from the progress made in the system standardization reviews in FY 2017 were conducted .
(iii) Worker Exposure Assessment	● Only a <b>simple assessment was conducted in FY 2016 to understand the tendency</b> in worker exposure, because, for worker exposure, a full assessment would require more detailed conditions such as layout. ● In FY 2017, <b>points of view regarding worker exposure were sorted out, and the existing nuclear facility was surveyed for settings such as classifications for the level of dose and contamination required for our review.</b> ● <b>Conditions to be reviewed were sorted out, including plant states at which exposure assessments are conducted (level of defense in depth) and areas accessible to workers, because, for worker exposure, assessments conducted under maintenance as well as normal operation conditions are important.</b>

**Worker exposure assessments are especially important for the feasibility of the retrieval process, therefore worker exposure is assessed with the progress in system standardization and layout study.**

## VI. (4) Study on Optimization of Ensuring Safety of Methods and Systems

### (ii) Study on Optimization of Ensuring Safety of Systems

#### (d) Categories of System Study Prerequisites and Their Standardization Status

The prerequisites in establishing the system have uncertainties. And system specifications and configurations change depending on the prerequisites (especially the state of the actual installation). However, **assumptions for multiple prerequisites are being made and systems that can meet these prerequisites in advance are being sorted out, so that system based on a standardized point of view can be selected, regardless of methods used, once the prerequisites are made clear.**

System Study Prerequisites		Status of Standardization*	Main Implementation Items Relating to System Study Prerequisites
Category	Type		
(i) Basic System Requirements Safety Requirements		No	-
	Functional Requirements	<b>Yes (Necessity of the oxygen concentration limit)</b>	<ul style="list-style-type: none"> <li>• Exposure assessment</li> <li>• Brushing up functional requirements</li> <li>• Reflecting the results of element technology development</li> </ul>
(ii) System Specifications	System Configurations	<b>Yes (Presence/absence of recirculation loops, presence/absence of multiplexing emergency systems, and support for temporary installation of emergency systems)</b>	<ul style="list-style-type: none"> <li>• Reflecting the results of element technology development</li> <li>• Reviewing system reliability</li> <li>• Reviewing maintenance policy</li> </ul>
	Equipment Specifications	No	<ul style="list-style-type: none"> <li>• Reflecting the results of element technology development</li> </ul>
(iii) System Layout	Layout Conditions	No	<ul style="list-style-type: none"> <li>• Reflecting the results of element technology development</li> <li>• Reconfiguring areas to which the system can be allocated</li> </ul>

\* Items to be determined at the actual design stage are excluded.

# VI. (4) Study on Optimization of Ensuring Safety of Methods and Systems

## (ii) Study on Optimization of Ensuring Safety of Systems

### (d) Categories of System Study Prerequisites and Their Standardization Status

- Standardization Status: Functional Requirement-Related Matters <Fire and Explosion Prevention: Necessity of the Oxygen Concentration Limit>

As an example of our standardization items, the following shows where setting prerequisites related to the prevention of fire and explosions are at.

#### ➤ Target Hydrogen Concentration

A standardized condition was set that the concentration should be less than the flammable concentration limit (4%). <Standardized Completed>

[Supplemental Information]

- If nitrogen is injected under the same conditions as the current ones (in terms of flow rate and injection point) in retrieving the fuel debris, the hydrogen concentration is generally expected to drop to a level lower than the current level. This is because of an additional diluting effect of the in-leak air caused by negative pressurization. For this reason, in our review last year, assumptions were made for addressing the hydrogen concentration under the same conditions of RPV nitrogen injection and PCV scavenging as the current ones.
- As the locations of hydrogen accumulation are unknown in this project, our plan is to confirm by analysis that nitrogen and in-leak air can sufficiently suppress the hydrogen concentration. Standardized judgement criteria (flow rate and injection point) for this functional requirement will be set based on the results of this analysis.

#### ➤ Target Oxygen Concentration

**Since** requirements for preventing combustion and explosions of flammable solid substances have not been clearly identified, multiple prerequisites were prepared. For this reason, multiple system configurations are being reviewed.

=> **“Differences in System Configurations” and “Future Implementation Plans” are shown in the following pages.**

Conditions Reviewed Last Year (Hydrogen and Oxygen Concentrations)

System Configurations (See the next page)	System Study Prerequisites	Notes
Plan 1	Hydrogen Concentration: < 4% <b>Oxygen Concentration: Not limited</b>	<b>Nitrogen is injected in an amount required for hydrogen delusion.</b>
Plan 2	Hydrogen Concentration: < 4% <b>Oxygen Concentration: Limited (as low as possible)</b>	<b>Nitrogen is injected in an amount required for oxygen delusion. (Increased nitrogen flow rate than Plan 1)</b>



## (ii) Study on Optimization of Ensuring Safety of Systems

### (d) Categories of System Study Prerequisites and Their Standardization Status

To prevent fire and explosions, **localized measures are also expected to be effective** as a method for reducing the oxygen concentration. Thus, reviews **in cooperation with the Fundamental Technology PJ** will be conducted. Also, the **oxygen concentration limit has an impact on corrosion control** and the increase in the amount of nitrogen injected to limit the oxygen concentration **has an impact on the monitoring capability for criticality (becomes more difficult as the amount of exhaust grows larger)**. Our judgment should take this correlation into account.

	Plan 1	Plan 2	Others (Using a Different Method)
Prerequisites (Functional Requirement)	Not Required to Reduce Oxygen Concentration	Required to Reduce Oxygen Concentration	Required to Reduce Oxygen Concentration
Image	<p>Nitrogen is injected as needed near the locations where the presence of hydrogen accumulation is expected (as a measure against hydrogen)</p>	<p>A large amount of nitrogen is injected to dilute the oxygen concentration in the entire PCV</p> <p>Nitrogen is also injected as needed near the locations where the presence of hydrogen accumulation is expected</p>	<p>Nitrogen is injected as needed near the cutting points</p> <p>Local Collector (Effective for Particle Dispersion Prevention)</p>
Overview	<p>Fill in nitrogen in an amount required for hydrogen dilution in locations where the presence of hydrogen accumulation is expected.</p> <p>(This serves as a measure against hydrogen only. Explosions of flammable solid substances are not taken into account.)</p>	<p>Fill in nitrogen in a large amount (as compared to the in-leak amount) to reduce the oxygen concentration in a wide area of space in the PCV and prevent explosions of flammable solid substances.</p>	<p>Combine nitrogen injection near the cutting point and a local collector to prevent a localized drop in the oxygen concentration + powder dust dispersion and prevent explosions of flammable solid substances.</p>
Features	<ul style="list-style-type: none"> <li>Amount of nitrogen to fill: Small (up to 40 m<sup>3</sup>/h)<sup>*1</sup></li> <li>Range of area where reduction of oxygen concentration is required: None in particular<sup>*2</sup></li> <li>Serves as a measure against hydrogen only</li> </ul> <p>*1 Similar to the current condition. *2 The in-leak amount may impact the concentration.</p>	<ul style="list-style-type: none"> <li>Amount of nitrogen to fill: Large (up to 1000 m<sup>3</sup>/h)</li> <li>Range of area where reduction of oxygen concentration is required: Entire PCV<sup>*3</sup> and <sup>*4</sup></li> <li>Serves also as a measure against hydrogen</li> </ul> <p>*3 The oxygen concentration is dependent on the in-leak amount. *4 Except for areas near the in-leak points.</p>	<ul style="list-style-type: none"> <li>Amount of nitrogen to fill: From small to large (to be reviewed going forward)</li> <li>Range of area where reduction of oxygen concentration is required: Areas near the cutting points<sup>*5</sup></li> <li>Requires separate measures against hydrogen</li> </ul> <p>*5 This assumes a local collector is installed.</p>

# VI. (4) Study on Optimization of Ensuring Safety of Methods and Systems

## (ii) Study on Optimization of Ensuring Safety of Systems

### (d) Categories of System Study Prerequisites and Status of Standardization

[Future Implementation Plans]

- The conditions required to prevent explosions of flammable solid substances will be set.
- In case that the reduction of the oxygen concentration is required, countermeasures including localized measures continues to be considered. (=> Need to coordinate with the Fundamental Technology project)
- Since the oxygen concentration reduction method depends on the in-leak amount as well as the amount of nitrogen to fill, countermeasures will be reviewed based on the results of element technology development for confinement (i.e. information on the openings of the actual installation and airflow analysis results [verification of the effectiveness of hydrogen accumulation prevention]).
- As the oxygen concentration affects corrosion control, and increased nitrogen is injected to limit the oxygen concentration affects the monitoring capability for criticality, an evaluation study for a comprehensive decision will be conducted.

<System Study Flow for the Necessity of Oxygen Concentration Limit>

